

OWNER'S MANUAL

and Installation Instructions

Series Impact-36G

AIR-COOLED RECREATIONAL VEHICLE GENERATORS

Model No. 00802-3

GENERAC[®]
POWER SYSTEMS, INC.

GENERAL SAFETY RULES



THE MANUFACTURER SUGGESTS THAT THESE "RULES" FOR SAFE OPERATION BE COPIED AND POSTED IN POTENTIAL HAZARD AREAS OF THE RECREATIONAL VEHICLE. SAFETY SHOULD BE STRESSED TO ALL OPERATORS AND POTENTIAL OPERATORS OF THIS EQUIPMENT.



Study these SAFETY RULES carefully before operating or servicing applicable equipment. Become familiar with this Owner's Manual and with your generator. Safe, efficient and reliable operation can only be achieved if generator is properly installed, operated and maintained. Many accidents are caused by failing to follow simple and fundamental rules or precautions. The manufacturer suggests that these GENERAL SAFETY RULES be copied and posted in potential hazard areas of the recreational vehicle. Safety should be stressed to all operators and potential operators of equipment.

The manufacturer cannot possibly anticipate every circumstance that might involve a hazard. The warnings in this Manual and on tags and decals affixed to the unit are, therefore, not all-inclusive. If you use a procedure, work method or operating technique Generac does not specifically recommend, you must satisfy yourself that it is safe for you and others. You must also make sure the procedure, work method or operating technique that you chose does not render the generator to be unsafe.



WARNING:



The engine exhaust from this product contains chemicals known to the State of California to cause cancer, birth defects, or other reproductive harm.

 For fire safety, the recreational vehicle generator must be properly installed and maintained. Installation must always remain in compliance with applicable codes and standards. In addition, the generator must be installed in conformance to the manufacturer's detailed installation instructions. Following installation, nothing must be done that might render the generator in noncompliance with such codes, standards and instructions.

 The RV generator produces extremely high and dangerous electrical voltages and can cause dangerous, and possibly fatal, electrical shock. Avoid contact with bare wires, terminals, etc. while the unit is running. If you must work around an operating generator, stand on an insulated, dry surface to reduce shock hazard.

- Never work on this equipment or handle any electrical device while standing in water, while barefoot, or while hands or feet are wet. Dangerous electrical shock will result.
- Have the generator properly grounded (bonded) during installation onto the vehicle, either by solid mounting to the vehicle frame or chassis or by means of an approved bonding conductor. DO NOT disconnect the bonding conductor, if so equipped. DO NOT reconnect the bonding conductor to any generator part that might be removed or disassembled during routine maintenance. If the grounding conductor must be replaced, use only a flexible conductor that is of No. 8 AWG copper wire minimum.

- In case of accident caused by electric shock, shut down the source of electrical power down at once. If this cannot be done, free victim from live conductor. AVOID DIRECT CONTACT WITH THE VICTIM. Use a dry board, dry rope, or other non-conducting implement to free the victim from live conductor.

 Inspect fuel system frequently for leaks or damage. Repair or replace any damaged or leaking component immediately. Never attempt to change, alter or modify the generator fuel system in any way that might affect safety or compliance with applicable codes and standards.

- The generator engine gives off DEADLY carbon monoxide gas through its exhaust system. This dangerous gas, if breathed in sufficient concentrations, can cause unconsciousness or even death. This exhaust system must have been properly installed, in strict compliance with applicable codes and standards. Following installation, you must do nothing that might render the system unsafe or in non-compliance with such codes and standards. The generator compartment must be completely vapor sealed from vehicle interior. There must be no possibility of exhaust fumes entering the vehicle interior. Never operate this equipment with a leaking or defective exhaust system.

- Never use the generator or any of its parts as a step. Stepping on the unit can stress and break parts and may result in dangerous, fuel leakage, oil leakage, etc.

 Do not smoke around the generator. Wipe up any fuel, and oil immediately. Never leave oily or fuel soaked rags in the generator compartment or on the generator itself. Keep the area around the generator clean and free of debris.

 Adequate ventilation is required to expel toxic fumes and gasoline vapors from the generator compartment. Do not alter the installation of this equipment in any manner that might obstruct air and ventilation openings. Such openings must be kept clear and unobstructed.

- Keep hands, feet, clothing, etc., away from drive belts, fans and other moving parts of this equipment. Never remove any drive belt or fan guards while the unit is operating.

- Inspect the generator periodically. Repair or replace all damaged or defective parts immediately.

 These generators can be converted to use LP gas (propane) as a fuel. Liquid Propane gas is highly EXPLOSIVE. The gas is heavier than air and tends to settle in low areas where even the slightest spark can ignite the gas and cause an explosion.

 Before performing any maintenance on the generator set, disconnect its battery cables to prevent accidental start up. Disconnect the cable from the battery post indicated by a NEGATIVE, NEG or (-) first. Reconnect that cable last.

IDENTIFICATION RECORD

Please record the following information from the generator DATA DECAL or information decal.

- | | |
|-----------------------|------------------------|
| 1. Model Number _____ | 2. Serial Number _____ |
| 3. kW Rating _____ | 4. Rated Voltage _____ |
| 5. Phase _____ | 6. Hertz _____ |

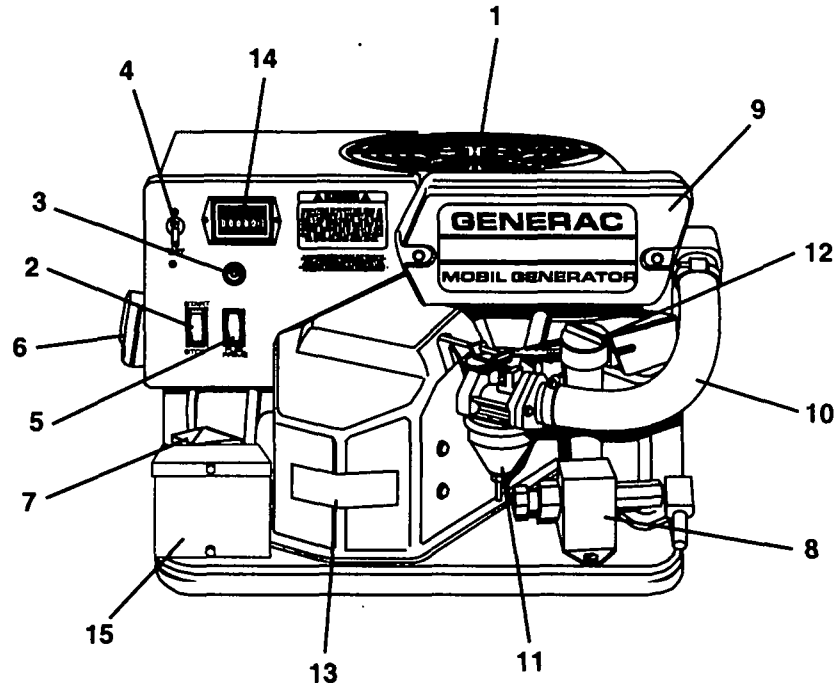

REFERENCE NUMBER IDENTIFICATION

- | | |
|--|----------------------------------|
| 1. Generator Air Intake Screen | 9. Air Cleaner |
| 2. Engine Start/Stop Switch | 10. Air Intake Tube |
| 3. Fuse | 11. Carburetor |
| 4. Circuit Breaker | 12. Oil Dipstick and Filler Tube |
| 5. Fuel Primer Switch | 13. Data Decal |
| 6. Generator AC Output Leads | 14. Hour Meter |
| 7. 12 Volt Battery Connection (Partially hidden by 15) | 15. Ignition Coil Assembly |
| 8. Fuel Pump | |

TABLE OF CONTENTS

OPERATING INSTRUCTIONS	
GENERAL SAFETY RULES	inside cover
IDENTIFICATION RECORD	1
GENERATOR FEATURES	1
READ THIS MANUAL THOROUGHLY	
Operation and Maintenance	3
How to Obtain Service	3
Service Dealer Location	3
GENERATOR FAMILIARIZATION	
Generator Applicability	4
Safety	4
Generator AC Connection System	4
OPERATING INSTRUCTIONS	
Generator Control Panel	5
Automatic Choke	5
Before Starting the Engine	5-6
Starting	6
Stopping the Generator	6
Applying Loads to Generator	6
Attention Required After Submersion	6
Operation in High Grass or Brush	6
Operating Precautions	6-7
Effects of Moisture and Dirt	7
Don't Overload the Generator	7
ENGINE PROTECTIVE DEVICES	
Automatic Low Oil Pressure Shutdown	7
High Temperature Shutdown	7
Overspeed	7
Low Voltage	7
SPECIFICATIONS	
Fuel Requirements	8
Engine Oil Requirements	8
Generator Specifications	8
Engine Specifications	8
MAINTENANCE	
Checking Engine Oil Level	9
Change Engine Oil	9
Change oil filter	9
Engine Air Cleaner	9-10
Clean Air Intake Screen	10
Spark Arrestor Muffler	10
Engine Spark Plug	10
Fuel Filter	10
Cleaning the Generator	11
Battery	11
Service and Adjustments	11
Throttle Linkage Adjustment	11-12
Adjusting the Carburetor	12
Adjusting Valve Clearance	12
Major Service Manual	13
Exercising the Generator	13
Out of Service Protection	13
Return the Unit to Service after Storage	13
Service Dealer Location	13
INSTALLATION INSTRUCTIONS	
INSTALLATION SAFETY RULES	14
GENERAL INSTALLATION INFORMATION	
Purpose and Scope	15
Safety	15
Standards Booklet	15
Equipment Description	15
Engine Generator Operating Speed	15
Generator AC Connection System	15
LOCATION AND SUPPORT	
Generator Location	16
Generator Support	16
Suspended Mounting	16
Generator Restraint	17
GENERATOR COMPARTMENTS	
Compartments	17
Compartment Size	18
Compartment Construction	18
Sound Insulation Materials	18
Compartment Floor Cutouts	19
Acoustics	19
COOLING AND VENTILATION AIR	
Generator Air Flow	20
Cooling Air Inlet Openings	20
Compensating for Restrictions	21
Testing the Installation	21
GASOLINE FUEL SYSTEM	
Fuel Tank	22
Generator Fuel Supply Line	22-23
EXHAUST SYSTEM	
Mufflers and Spark Arrestors	23
Type of Exhaust System	23
Exhaust System Safety	23
ELECTRICAL CONNECTIONS	
Electrical Junction Box	24
Wiring	24
Generator AC Connections	24
Conduit	24
Isolating Different Power Sources	25
Power Supply Cord	25
Ground Fault Circuit Interruptors	25
BATTERY INSTALLATION	26-27
OPTIONAL ACCESSORIES	28
POST INSTALLATION TESTS	29
INSTALLATION CHECK LIST	30
TROUBLESHOOTING	31
MAJOR FEATURES AND DIMENSIONS	32
ELECTRICAL DATA	33
REPAIR PARTS	34 to 41
NOTES	42 - 43
CALIFORNIA EMISSIONS WARRANTY	44 - 45
WARRANTY	back page

READ THIS MANUAL THOROUGHLY

If you don't understand any portion of this manual, contact Generac for a demonstration of actual starting, operating and servicing procedures.

Throughout this publication and on tags and decals affixed to the generator, DANGER, WARNING, CAUTION and NOTE blocks are used to alert you to special instruction about a particular operation that may be hazardous if performed incorrectly or carelessly. Observe them carefully.

These safety warnings cannot eliminate the hazards that they indicate. Strict compliance with the special instructions while performing the service plus "common sense" are major measures to prevent accidents.

The following definitions apply to DANGER WARNING, CAUTION and NOTE blocks found throughout the manual.



DANGER: Indicates an immediately hazardous situation which, if not avoided, will result in death or serious injury. Danger is limited to the most extreme situations.



WARNING: Indicates a potentially hazardous situation which, if not avoided, could result in death or serious injury.



CAUTION: Indicates a potentially hazardous situation which, if not avoided, may result in minor or moderate injury. Caution may also be used to alert against unsafe practices.

NOTE: Indicates a statement of company policy as the message relates directly or indirectly to the safety of personnel or protection of property.

These symbols indicate the following:



Points out important safety information and, if not followed, could endanger personal safety and/or property of yourself and others.



Potential explosion hazard



Potential fire hazard



Potential electrical shock hazard

The operator (driver) is responsible for proper and safe use of the vehicle, equipment on the vehicle, and the safety of all vehicle occupants. We strongly recommend that the operator read this Owner's Manual and thoroughly understand all instructions before using this equipment. We also strongly recommend instructing other occupants in the vehicle to properly start and operate the generator. This prepares them if they need to operate the equipment in an emergency.

OPERATION AND MAINTENANCE

It is the operator's responsibility to perform all safety checks; to make sure that all maintenance for safe operation is performed promptly; and to have the equipment checked by an Authorized Dealer periodically. Normal maintenance service and replacement of parts are the responsibility of the Owner/Operator and, as such, are not considered defects in materials or workmanship within the terms of the warranty. Individual operating habits and usage contribute to the need for maintenance service.

Proper maintenance and care of your industrial mobile generator assures a minimum number of problems and keeps your operating expenses at a minimum. See your authorized Dealer/Distributor for service aids and accessories.

HOW TO OBTAIN SERVICE

When your mobile generator set requires servicing or repairs, simply contact an Authorized Service Facility for assistance. Service technicians are factory-trained and are capable of handling all of your service needs.

When contacting an Authorized Service Facility or the factory about parts and service, always supply the complete model number and serial number of your unit as given on its data decal.

The warranty on your generator is included in this Owner's Manual, as well as listings for repair parts.

SERVICE DEALER LOCATION

TO LOCATE THE NEAREST GENERAC SERVICING DEALER, PLEASE CALL OUR 800 NUMBER.

ONLY DEALER LOCATION INFORMATION CAN BE OBTAINED AT THIS NUMBER.

1-800-333-1322

GENERATOR FAMILIARIZATION

GENERATOR APPLICABILITY

These generators have been designed and manufactured for supplying electrical power for recreational vehicles. You should not modify the generator or use it for any application other than for what it was designed. If there are questions pertaining to its application, write or call the factory. Do not use the unit until you have been advised by a competent authority.



DANGER: For fire safety, the generator must have been properly installed in compliance with (1) ANSI 119.2-1975/NFPA 501C-1974 "Standard for Recreational Vehicles", Part III, "Installation of Electrical Systems." The generator also must have been installed in strict compliance with the manufacturer's detailed installation instructions. After installation, do nothing that might render the unit in non-compliance with such codes, standards and instructions.

You can use this generator to supply electrical power for operating 120 volts, single phase, 60 Hertz, electrical loads. These loads can require up to 3600 watts (3.6 kW) of power for the NP-36G series. The maximum current at 120 volts is 30 amperes.



CAUTION: Do not overload the generator. Some installations may require that electrical loads be alternated to avoid overloading. Applying excessively high electrical loads may damage the generator and may shorten its life. Add up the rated watts of all electrical lighting, appliance, tool and motor loads the generator will power at one time. This total should not be greater than the wattage capacity of the generator. If an electrical device nameplate gives only volts and amps, multiply volts times amps to obtain watts (volts x amps = watts). Some electric motors require more watts of power (or amps of current) for starting than for continuous operation.

SAFETY

Before using the generator set, carefully read GENERAL SAFETY RULES inside the cover. Comply with these RULES to prevent accidents and damage to equipment and/or property. Generac suggests copying and posting the GENERAL SAFETY RULES in potential hazard areas of the recreational vehicle. Safety should be stressed to all operators of this equipment.

GENERATOR AC CONNECTION SYSTEM

These air-cooled NP Series generator sets power 120-volt, 30 amp AC loads for the NP-36G model. The diagram below is a simple schematic (Figure 1) of the generator's AC connection system.

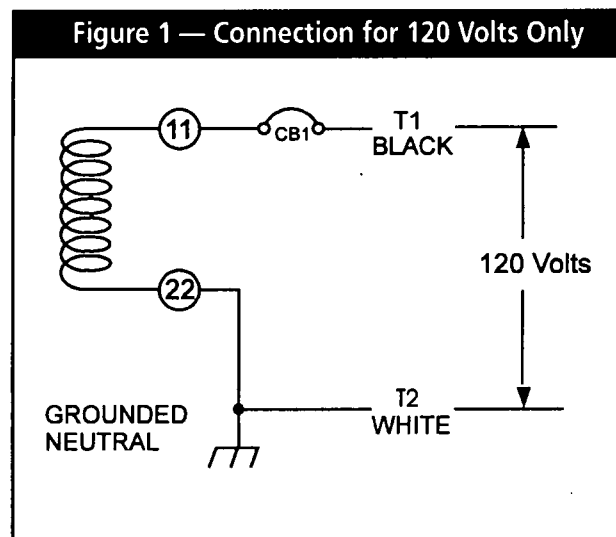

OPERATING INSTRUCTIONS

GENERATOR CONTROL PANEL

Mounted on the generator control panel (Figure 2) are the following features:

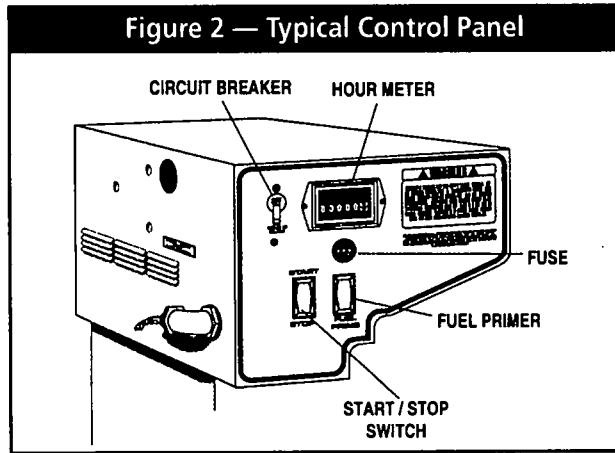

■ FUEL PRIMER

Before starting a cold engine you must press this switch to bring fuel from the tank to the carburetor. This rocker type switch springs back into its original position when you release it.

■ START/STOP SWITCH

To crank and start the engine, hold this switch at its START position. Release the switch when the engine starts. To stop an operating engine, press and hold the switch in its STOP position until the engine shuts off. The switch center position is the RUN position.

■ FUSE

Protects the engine DC control circuit against electrical overload. If the fuse element has melted open due to overloading, the engine cannot be cranked. If you must replace it, use only an identical replacement fuse.

■ CIRCUIT BREAKER

Protects generator's AC output circuit against overload, i.e., prevents unit from exceeding wattage/ampere capacity.

■ HOUR METER

Indicates the time the engine-generator has operated, in hours and tenths of hours. Use the hourmeter along with the periodic maintenance schedule for your generator set.

AUTOMATIC CHOKE

The engine is equipped with an automatic choke that consists of two main components — choke solenoid and prechoke.

■ CHOKE SOLENOID

During engine cranking (start/stop switch at START), a solid state choke module signals the choke solenoid to actuate and cycle (choke on/choke off) until engine starts. The choke solenoid thus opens and closes the carburetor choke valve only when the engine is cranking. When the engine starts, the choke cycling stops.

■ PRECHOKE

The choke system also has a temperature sensitive metal strip that adjusts the choke valve angle according to ambient temperatures (i.e., in cold ambient temperatures the choke valve closes more). Once the engine starts, an element heats the temperature-sensitive strip to a normal operating condition, opening the choke valve. This may take about 3 minutes in cooler weather.

BEFORE STARTING THE ENGINE

IMPORTANT: INSTRUCTIONS AND INFORMATION IN THIS MANUAL ASSUME THE GENERATOR HAS BEEN PROPERLY INSTALLED, CONNECTED, SERVICED, TESTED AND ADJUSTED BY A QUALIFIED INSTALLATION TECHNICIAN OF INSTALLATION CONTRACTOR.

■ INSTALLATION

Generator installation must have been properly completed so it complies with all applicable codes, standards and regulations and with the manufacturer's recommendations.

■ ENGINE LUBRICATION

Have engine crankcase properly serviced with recommended oil before starting. Refer to "Maintenance" and "Specifications" sections for oil servicing procedures and recommendations.



CAUTION: Any attempt to crank or start the engine before you have properly serviced it with the recommended oil may result in engine failure.

■ FUEL SUPPLY

The engine must have adequate supply of proper fuel to operate. Before starting, check that sufficient fuel is available.

NOTE: On some installations, the generator engine may "share" the vehicle's gasoline fuel tank with the vehicle engine. Some installations may provide separate fuel tanks for generator and vehicle engine.

■ COOLING AND VENTILATING AIR

Air inlet and outlet openings in the generator compartment must be open and unobstructed for continued proper operation. Without sufficient cooling and ventilating air flow, the engine-generator quickly overheats, which causes it to automatically shutdown. Overheating could also damage the unit or your vehicle.

■ ENGINE EXHAUST GAS

Before starting the generator engine, you should be sure there is no way for exhaust gases to enter the vehicle interior and endangering people or animals. Close windows, doors and other openings in the vehicle that, if open, might permit exhaust gases to enter the vehicle.



DANGER: The generator engine gives off deadly carbon monoxide gas through its exhaust system. This dangerous gas, if breathed in sufficient concentrations, can cause unconsciousness or even death. Do not operate the generator if its exhaust system is leaking or has been damaged. Symptoms of carbon monoxide poisoning are (inability to think coherently, (b) vomiting, (c) twitching muscles, (c) throbbing temples, (e) dizziness, (f) headache, (g) weakness and sleepiness. If you feel any of these symptoms, move into fresh air immediately. If symptoms persist, get medical help.

STARTING

IMPORTANT: Read the vehicle manufacturer's instructions. The owner/operator should become familiar with the vehicle in which this generator is installed. Differences exist between vehicles. For example, some vehicles may use a transfer switch to isolate dockside power from the generator, while other vehicles may use an isolating receptacle. Some vehicles may be equipped with a DC converter which allows the generator to power certain DC lighting and other DC loads.

To crank and start the generator engine, proceed as follows:

1. Turn OFF electrical loads, using whatever means provided in your vehicle (such as a main line circuit breaker or transfer switch).

NOTE: If you start the engine with the start/stop switch on the generator control panel, turn OFF loads by setting the panel's main breaker to its "OFF" or "OPEN" position. Electrical load circuits will be turned ON after the generator has started, stabilized and warmed up.

NOTE: You only need to use the fuel primer during the initial startup, after the unit has not been used for an extended period of time or the fuel line has been disconnected. The primer is used to prime the fuel pump and carburetor.

2. To crank and start the engine, hold the start/stop switch at START. Release the switch when the engine starts.



CAUTION: If the engine does not start after it has been cranking for 15 seconds, release the start/stop switch and try again. Holding the switch for longer than 15 seconds may damage the starter motor.

3. Let the engine run at no-load for a few minutes to stabilize and warm up the engine.

4. Turn ON electrical loads, using whatever means provided (such as a main circuit breaker or transfer switch).

NOTE: If you start a warm generator engine, you may press the start switch only slightly to engage the ignition system. However, you should press and hold the starter switch for a minimum of two (2) seconds to energize the field boost system. If you start the engine without energizing the field boost system, the generator produces no AC output.

STOPPING THE GENERATOR

1. Turn OFF all electrical loads, using whatever means provided (such as a main circuit breaker or transfer switch).
2. Let the generator run at no-load for a few minutes, to stabilize internal engine-generator temperatures.
3. Hold Start/Stop switch in its STOP position.

APPLYING LOADS TO GENERATOR

When applying electrical loads to the generator, observe these guidelines:

- Before applying electrical loads, let the generator stabilize and warm up for a minute or two.
- DO NOT overload the generator.

■ LETTING ENGINE STABILIZE

The generator supplies correctly rated frequency and voltage only at the proper governed speed. Some electrical appliances may be extremely sensitive to voltage and frequency. Incorrect frequencies and/or voltages can damage those appliances.

If electrical loads are applied at reduced operating speeds, such loads imposed on the engine when sufficient power is not available may shorten engine life. Never turn ON electrical loads until after the generator engine has started and stabilized ON-speed.

ATTENTION REQUIRED AFTER SUBMERSION

If the motor home generator has been submerged in water, it must NOT be started or operated. Following any submersion in water, have an authorized Generac Service Facility thoroughly clean and dry the generator.

OPERATION IN HIGH GRASS OR BRUSH

Never operate the generator while the vehicle is parked in high grass, weeds, brush or leaves. Such materials can ignite and burn from the heat of the exhaust system. The generator exhaust system becomes extremely hot during operation and remains hot for a long time after it has shut down.

OPERATING PRECAUTIONS

Never operate the motor home generator set while the vehicle is parked over dry leaves, dry grass or any other combustible substance. The generator's exhaust system becomes extremely hot and can cause a fire if it is too close to combustible materials.

The generator's exhaust system gives off DEADLY carbon monoxide gas. This dangerous gas, if breathed in sufficient concentrations, can cause unconsciousness and even death. Never operate the generator set with the vehicle inside any garage or other enclosed area. Never operate the generator if it has a leaky exhaust system. Close windows in the vicinity of the generator exhaust outlet and take any other steps to prevent exhaust gases from entering rooms or areas occupied by people or animals.

EFFECTS OF MOISTURE AND DIRT

Keep the generator set as clean and dry as possible. Protect unit against excessive dust, dirt, corrosive vapors, road splash, etc. Permitting dirt and moisture to accumulate on generator windings will have an adverse effect on the insulation resistance of those windings.

When moisture is allowed to remain in contact with windings, some of the moisture will be retained in voids and cracks in the insulation. This causes a reduced insulation resistance and will eventually cause problems. Dirt will make the problem worse, since dirt tends to hold moisture in contact with windings. Salt (as from sea air) will also worsen the problem since it tends to absorb moisture from the air. Salt and moisture, when combined, form a good electrical conductor.

DO NOT OVERLOAD THE GENERATOR

You can read the rated wattage/ampere capacity of your generator on the generator data decal (see "Identification Record" on Page 1).

Applying electrical loads in excess of the unit's rated capacity will cause the engine-generator to automatically shutdown.

To avoid overloading, add up the wattage of all connected electrical lighting, appliance, tool and motor loads. This total should not be greater than the generator's rated wattage capacity.

- Most lighting, appliance, tool and motor loads indicate their required watts on their nameplate or data plate. For light bulbs, simply note the wattage rating of the bulb.
- If a load does not show its rated wattage, multiply that load's rated VOLTS times AMPS to obtain WATTS.
- Induction type motors (such as those that run the vehicle's furnace fan, refrigerator, air conditioner, etc.) need about 2-1/2 times more watts of power for starting than for running (for a few seconds during motor starting). Be sure to allow for this when connecting electrical loads to the generator. First, figure the watts needed to start electric motors in the system. To that figure, add the running wattages of other items that will be operated by the generator.
- On a new generator do not apply heavy electrical loads for the first two or three hours of operation.

ENGINE PROTECTIVE DEVICES

This generator has a computer that monitors low oil pressure, oil temperature, engine speed, and low voltage output. This section discusses those protective devices.

AUTOMATIC LOW OIL PRESSURE SHUTDOWN

The engine is equipped with an oil pressure sensor that shuts down the engine automatically when oil pressure is too low. If the engine shuts down by itself and the fuel tank has enough gasoline, check the engine oil level.

■ INITIAL STARTUP

During initial startup, a time delay built into the shutdown control system allows oil pressure to build. The delay allows the engine to run for about 10 seconds before sensing oil pressure.

■ SENSING LOW PRESSURE

If the system senses low oil pressure during operation, the engine shuts down. If you do restart the engine after a low oil pressure shutdown and have not corrected the low oil level, the engine runs for about 10 seconds as described above then stops.

HIGH TEMPERATURE SHUTDOWN

A temperature switch with normally-open (N.O.) contacts is mounted near the oil filter. If engine temperature were to exceed a preset temperature, the switch contacts close and the engine shuts down.

OVERSPEED

If engine speed is increased manually (or otherwise) beyond the control of the computer control system, the computer disables the load capability of the generator and shuts down the engine.



WARNING: Do not attempt to physically adjust or control the engine speed. Equipment damage or personal injury may result.

LOW VOLTAGE

The computer monitors the voltage output of the generator. If voltage sensors indicate that voltage has dropped below a preset level, the engine will automatically shut down. Once the unit has shutdown, the computer is automatically reset when you restart the engine.

NOTE: The computer allows for the low voltage output that occurs during startup. A time delay that allows the engine to start and warm up is programmed into monitoring the system.



CAUTION: Before restarting a generator that has been shutdown, disconnect all loads the generator might power by whatever means provided, such as the recreational vehicle's main circuit breaker.

SPECIFICATIONS

FUEL REQUIREMENTS

These generators are equipped with gasoline fuel systems as standard equipment. Specific installations may provide either a separate fuel tank for the generator, or the generator may "share" the vehicle engine's fuel tank.

NOTE: Installations using a "shared" fuel tank may have a generator fuel pickup tube that is shorter than the vehicle engine's pickup tube. Such an arrangement causes the generator engine to "run out of gas" while adequate fuel for the vehicle remains in the tank.

To reduce lead and carbon deposits use high quality UNLEADED gasoline with the generator. Leaded REGULAR grade gasoline is an acceptable substitute.

NOTE: Using "Unleaded" gasoline contributes to longer engine valve life by reducing lead and carbon deposits.



CAUTION: Generac does not recommend using any gasoline containing alcohol, it must not contain more than 10 percent ethanol and it must be removed from the generator during storage. Do NOT use any gasoline containing methanol. If you use gasoline with alcohol, inspect more frequently for fuel leaks and other abnormalities.

FUEL CONSUMPTION (IN GALLONS PER HOUR):

LOAD	GASOLINE
NO	0.13
HALF	0.20
FULL	0.40

ENGINE OIL REQUIREMENTS

The recommended oils include the following:

- During summer months: SAE 30. An acceptable substitute is SAE 10W-30.
- During winter months: SAE 5W30. DO NOT USE SAE 10W-40.

Crankcase and oil filter capacity is about 950ml or one (1) quart. Use no special additives. See "Maintenance" section for oil level check and fill procedures.

GENERATOR SPECIFICATIONS

Model.....Impact-36G
 Rated Maximum Continuous
 AC Power Output3600 watts (3.6 kW)
 Rated Voltage120 volts AC
 Rated Maximum Continuous
 Current at 120 volts30 AC amperes
 Phase.....Single Phase
 Rated AC Frequency60 Hz.
 Maximum Battery
 Recommended Battery
 Cranking Current400 amps

ENGINE SPECIFICATIONS

Type of EngineGN-220
 Cooling Method.....Air-cooled
 Displacement.....220cc
 Type of GovernorElectronic
 Air Cleaner.....Paper element
 Starter12 volt DC electric
 Ignition System.....Solid state
 Recommended Spark Plugs.....Champion RC12YC
 Spark Plug Gap.....0.030 inch (0.8mm)

This section includes information about simple maintenance which includes the following tasks:

- Checking engine oil level.
- Changing engine oil.
- Changing oil filter.
- Changing the air cleaner.
- Cleaning the air intake screen.
- Cleaning spark plug.

CHECKING ENGINE OIL LEVEL

Check engine crankcase oil level at least every eight hours of operation, or before each use (Figure 3).

- Be sure the generator is as level as possible.
- Remove oil dipstick and wipe dry with clean, lint-free cloth.
- Install and tighten oil dipstick, then remove again.
- Oil should be at dipstick FULL mark. If necessary, add the recommended oil to the FULL mark only. **DO NOT FILL ABOVE "FULL" MARK.**
- Install and tighten oil dipstick cap before operating the engine.

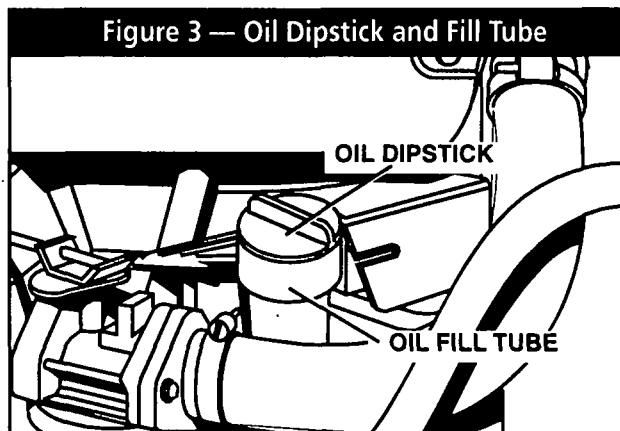

NOTE: See "Engine Oil Requirements" on Page 8 for recommended oils.

CHANGE ENGINE OIL

Change engine oil after the first 8 hours of operation. Thereafter, change oil every 50 operating hours. Change oil more frequently if operating consistently under heavy load or at high ambient temperatures.

- Warm up engine for at least five minutes, then shut down.
- With engine still warm from running, clean area around oil drain plug and remove oil drain plug (Figure 4). Drain oil completely into a suitable container.
- When oil has drained, install and tighten drain plug.
- Remove oil dipstick and fill crankcase with the recommended oil (See Page 8). The engine crankcase can hold about 1 quart (950ml). **DO NOT FILL ABOVE "FULL" MARK.**

- Install and tighten dipstick cap before operating engine.

CHANGE OIL FILTER

Replace the engine oil filter after the first 8 hours of operation, every 50 operating hours thereafter.

- Turn oil filter counterclockwise to remove (Figure 4).

Figure 4 — Oil Drain Plug and Engine Oil Filter

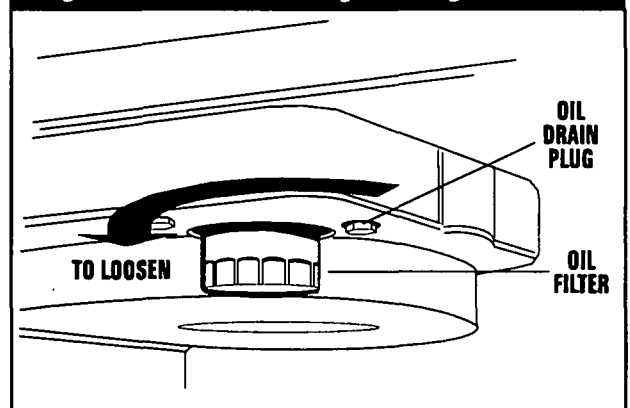

- Coat gasket of new filter with engine oil.
- Turn new filter clockwise until its gasket contacts lightly with the filter adapter. Then tighten with an additional 3/4 to one turn by hand.
- Run engine and check for leaks.

NOTE: Check oil level and fill to full mark after checking for leaks. Filter will retain some oil.

ENGINE AIR CLEANER

Paper Filter: Once every 25 operating hours or once each year (whichever comes first), clean or replace the paper filter (Figure 5). Follow the steps on page 10:

Figure 5 — Engine Air Cleaner Assembly

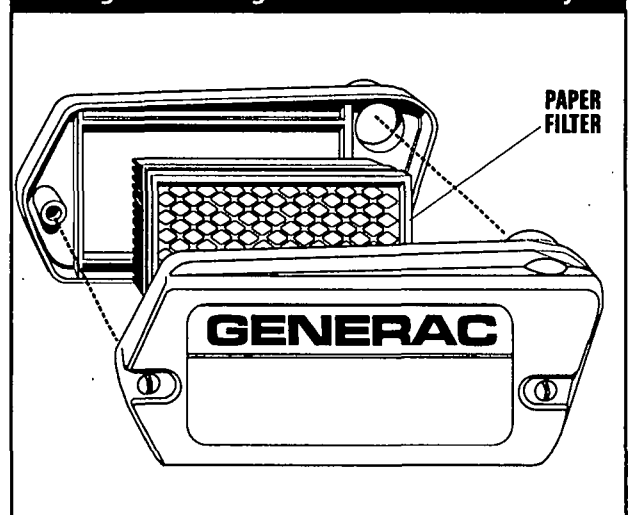

- Remove air cleaner cover, then remove paper filter.
- Clean air filter by gently tapping it on a solid surface. If the filter is too dirty, replace it with a new one. Dispose of the old filter properly.
- Clean air cleaner cover then insert new paper filter into cover and assemble to the base of the air cleaner.

CLEAN AIR INTAKE SCREEN

Clean all foreign material from the air intake screen (Figure 6) at least once every 100 hours of operation. Clean more often if necessary.

Inspect the area around the generator exhaust muffler periodically and remove all grass, leaves, dirt, etc. from this area.

Figure 6 — Clean Air Intake Screen

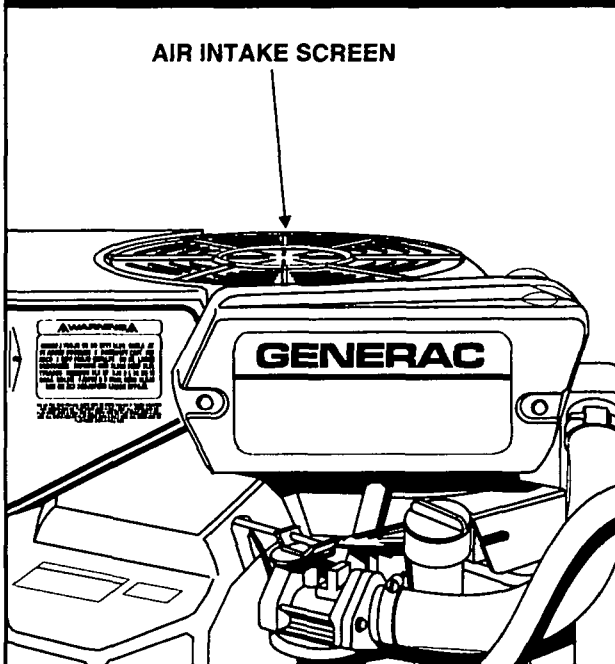

ENGINE SPARK PLUG

Clean engine spark plug and set gap to 0.030 inch (0.76mm) every 100 hours of operation (Figure 7). Clean by scraping or wire brushing and washing with commercial solvent. DO NOT BLAST CLEAN SPARK PLUG.

Figure 7 — Setting Gap on Spark Plug

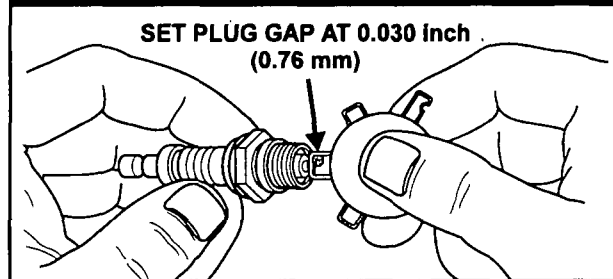

CAUTION: Sparking can occur if wire terminal does not fit firmly over spark plug terminal end. If necessary, reform wire terminal to obtain a tight fit.

FUEL FILTER

Remove and replace fuel filter (Figure 8) every 100 hours of operation or once each year, whichever occurs first.

Figure 8 — Fuel Filter

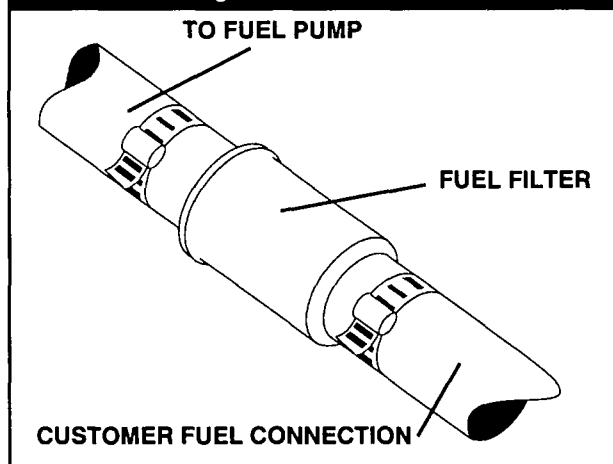

CLEANING THE GENERATOR

Keep your generator set as clean and dry as possible. Dirt and moisture that are permitted to accumulate on electrical windings have an adverse effect on the insulation resistance of those windings.

Moisture that is allowed to remain in contact with windings will be retained in voids and cracks of the windings. Dirt makes the problem worse, since it tends to hold the moisture into contact with the windings. Salt, as from sea air, worsens the problem since it tends to absorb moisture from the air. The combination of salt and moisture makes a good electrical conductor.



CAUTION! Do NOT use a forceful spray of water to clean the generator. Water will enter the generator interior and cause problems, and may also contaminate the generator fuel system.

BATTERY

All lead-acid storage batteries will discharge when not in use. Inspect the generator battery as follows:

■ ONCE WEEKLY

Inspect battery posts and cables for tightness, corrosion. Clean and/or tighten as necessary.

Also check battery fluid level, and, if necessary, fill with **DISTILLED WATER ONLY**. **DO NOT USE TAP WATER IN BATTERY.**

■ EVERY SIX MONTHS

Have the battery state of charge and condition checked by an automotive service facility. This should be done with an automotive type battery hydrometer.



DANGER: Storage batteries give off explosive hydrogen gas. This gas can form an explosive mixture around the battery for several hours after charging. The slightest spark can ignite the gas and cause an explosion. Such an explosion can shatter the battery and cause blindness or other injury. Any area that houses a storage battery must be properly ventilated. Do not allow smoking, open flame, sparks or any spark producing tools or equipment near the battery.



DANGER: Battery electrolyte fluid is an extremely caustic sulfuric acid solution that can cause severe burns. Do not permit fluid to contact eyes, skin, clothing, painted surfaces, etc. Wear protective goggles, protective clothing and gloves when handling a battery. If you spill the fluid, flush the affected area immediately with clear water.



DANGER: Do not use any jumper cables or booster battery to crank and start the generator engine. If any battery has discharged, remove it from the vehicle for recharging.

SERVICE AND ADJUSTMENTS

■ ENGINE SPEED

Engine speed is completely computer-controlled. There is no adjustment for speed on the unit. The computer adjusts the engine speed using an electronic governor throttle control. The computer monitors the demand for power and adjusts the engine speed accordingly. This allows the engine to produce only the power required, resulting in fuel economy as well as lowering the overall noise emitted.

NOTE: The computer will disable the electrical load capabilities of the generator and enter a fault condition if you accelerate the throttle manually or any other way.

THROTTLE LINKAGE ADJUSTMENT

If needed, you can adjust the length of the linkage rod between the electronic governor lever arm and the carburetor throttle lever arm. This adjustment helps to establish the proper travel relationship between the two lever arms. If this adjustment is not properly set, the computer will NOT have control of the full range of engine speed. If the rod adjustment is set too short, the computer will not have access to wide open throttle or "full power" conditions. If the rod adjustment is set too long, the computer will not have access to closed throttle or "no power" conditions.

Use the following procedure to assure the linkage rod is properly adjusted:

1. Start the generator, then shut it down right away. As the engine coasts to a stop, observe from above the engine as the throttle lever on the carburetor rotates counter-clockwise.
2. There should be a gap of 0.003 inch (0.08-0.5mm) between stop tab on throttle lever arm and the stop block on the carburetor die casting (Figure 9).

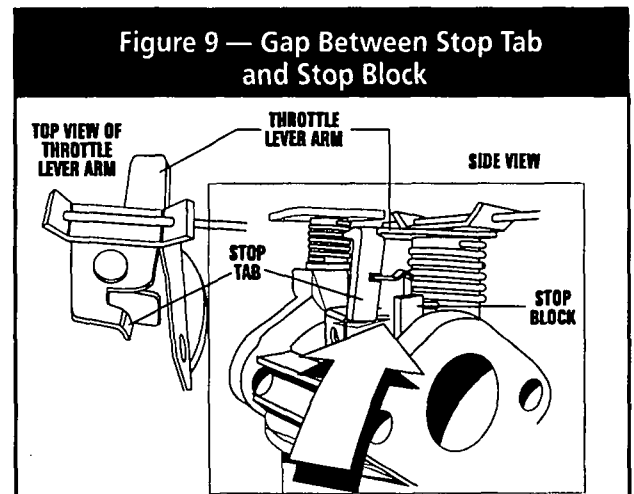

CAUTION: Do not overbend the spring clip or the clip will lose its clamping force.

3. With pliers, lightly compress the spring clip on the carburetor lever arm. This allows the linkage rod to slide freely through the clip. While the clip is compressed, rotate the throttle lever in the appropriate direction to increase or decrease the gap until there is 0.003 inch (0.08-0.5mm) clearance (Figure 10).

Figure 10 — Adjusting Throttle Linkage

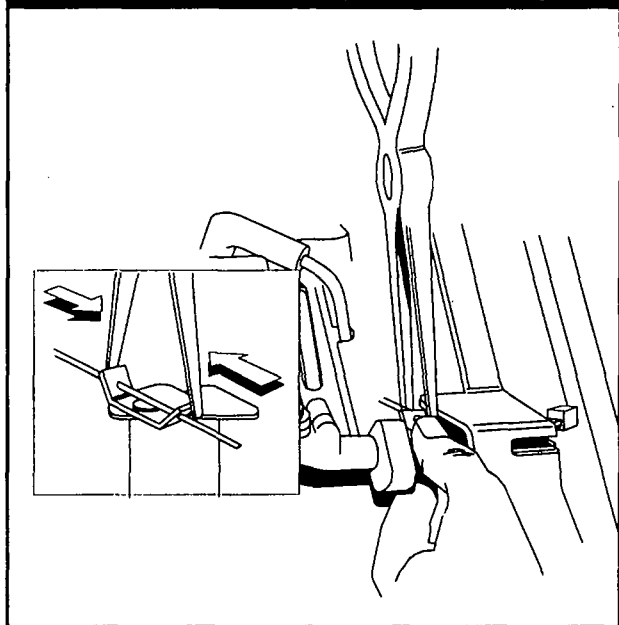

4. Release spring clip so you can secure adjustment. This allows the carburetor and the electronic governor to be synchronized.

ADJUSTING THE CARBURETOR

The carburetor of your generator is preset at the factory. The carburetor should not be tampered with, as this will void the emission control system warranty. If your generator is used at altitudes in excess of 5,000 feet, consult your Generac Authorized Service Facility regarding high altitude jetting changes.

ADJUSTING VALVE CLEARANCE

After the first 50 hours of operation, you should adjust the valve clearance in the engine.

When adjusting valve clearance, the engine should be at room temperature and the piston should be at Top Dead Center (TDC) of its compression stroke (both valves closed). Correct clearance is 0.001-0.003 inch (0.03-0.07mm). Adjust valve clearance as follows:

1. Loosen the rocker arm jam nut. Use an allen wrench to turn the pivot ball stud while checking clearance between the rocker arm and the valve stem with a feeler gauge (Figure 11).

Figure 11 — Adjusting Valve Clearance

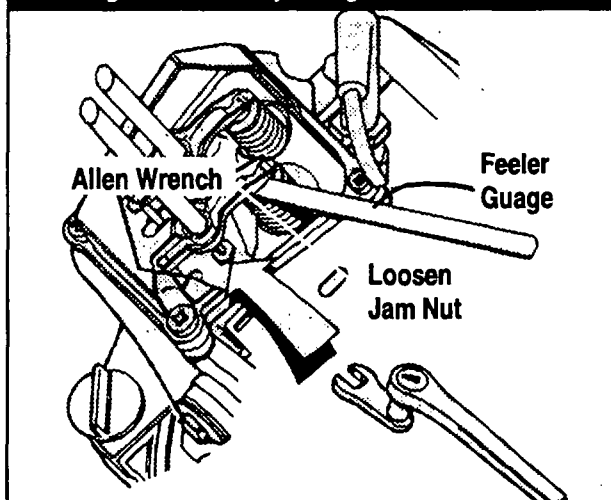

2. When valve clearance is correct, hold the pivot ball stud with the allen wrench and tighten the rocker arm jam nut with a crows foot. Tighten the jam nut to 65-85 inch-pounds torque. After tightening the jam nut, recheck valve clearance to make sure it did not change (Figure 12).

Figure 12 — Tightening Jam Nut

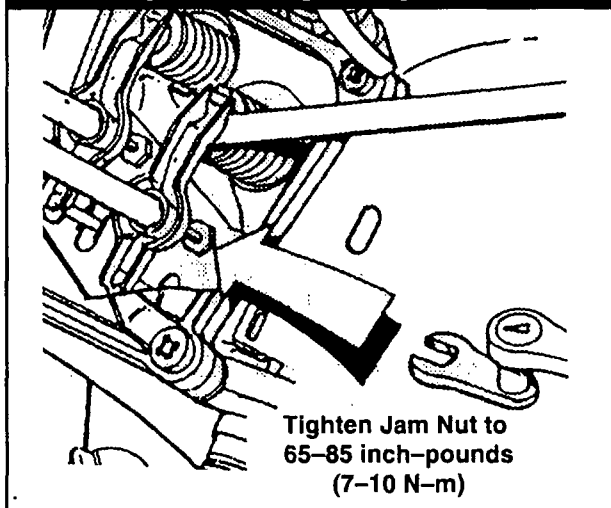

MAJOR SERVICE MANUAL

To obtain a service manual for your generator, order it from your dealer/distributor or contact the factory. Be sure to identify your unit's MODEL NUMBER and SERIAL NUMBER.

EXERCISING THE GENERATOR

Generac recommends that you start and operate the generator at least once every seven days. Let the unit run for at least 30 minutes to "exercise" the engine.

OUT OF SERVICE PROTECTION

If you cannot exercise the generator every seven days and it is to be out of service longer than 30 days, prepare the generator for storage as follows:

- Start the engine and let it warm up.
- While the engine is still warm from running, drain the oil completely. Refill crankcase with recommended oil. See "Specifications."
- Attach a tag to the engine indicating the viscosity and classification of the oil in the crankcase.
- Remove spark plug and add about 1/2 ounce (15ml) of clean, fresh engine oil into spark plug threaded openings. Crank engine several times to distribute oil, then install and tighten spark plug.
- Remove the battery and store in a cool, dry room on a wooden board. Never store the battery on any concrete or earthen floor.
- Clean and wipe the entire generator.

RETURN UNIT TO SERVICE AFTER STORAGE

To return the unit to service after storage, proceed as follows:

- Check tag on engine for oil viscosity and classification. Verify that the correct recommended oil is used in engine. If necessary, drain and refill with proper oil.
- Check battery. Fill all cells to the proper level with distilled water. DO NOT USE TAP WATER IN THE BATTERY. Recharge battery to 100% state of charge, or, if defective, replace the battery.
- Turn OFF all electrical loads, then start the engine.
- Let engine warm up.
- Apply electrical loads to at least 50% of the unit's rated wattage capacity.
- When engine is thoroughly warmed up, shut it down.

THE GENERATOR IS NOW READY FOR SERVICE.

SERVICE DEALER LOCATION

TO LOCATE THE NEAREST GENERAC SERVICING DEALER, PLEASE CALL OUR 800 NUMBER.

ONLY DEALER LOCATION INFORMATION CAN BE OBTAINED AT THIS NUMBER.

1-800-333-1322

INSTALLATION SAFETY RULES



DANGER: FOR FIRE SAFETY, INSTALLATION OF A GENERATOR INTO A RECREATIONAL VEHICLE MUST COMPLY STRICTLY WITH ARTICLE 551, NFPA 70; ANSI C1-1975; AND, ANSI A119.2-1975/NFPA 501C "STANDARD FOR RECREATIONAL VEHICLES" (PART 3, "INSTALLATION OF ELECTRICAL SYSTEMS"). IN ADDITION, THE MANUFACTURER'S INSTRUCTIONS AND RECOMMENDATIONS MUST BE COMPLIED WITH.



NOTICE TO INSTALLER

The Installation Instructions have been published by Generac Corporation to aid in the installation of the products described in this manual. Generac assumes that installation personnel are familiar with the procedures for installing such products, or similar products that Generac manufactures. Generac also assumes that personnel have been trained in the recommended installation procedures for these products and that such training includes (a) use of common hand tools, (b) use of special Generac tools, and (c) use of any tools and/or equipment from other suppliers.

We could not possibly know of and advise the recreational vehicle trade of all conceivable methods, procedures or techniques by which to perform an installation. We could not know of the possible hazards that might result from each installation method, procedure or technique. We have not undertaken any such wide evaluation. Therefore, people who use a method, procedure or technique that Generac does not specifically recommend must first completely satisfy themselves that their safety, the safety of the vehicle's occupants and the products's safety is not endangered by the method, procedure or technique selected.

Information, illustrations, specifications, etc., contained in this Installation Manual are based on the latest information available at the time of publication. Every effort has been expended to be sure that such data is both accurate and current. However, the manufacturer reserves the right to change, alter or otherwise improve this product at any time without prior notice.

SAFETY RULES

- ▲ Gasoline is extremely **FLAMMABLE** and its vapors are **EXPLOSIVE**. Do not permit smoking, open flame, sparks or any source of heat in the vicinity while handling gasoline. Comply with all laws governing the storage and handling of gasoline.
- ▲ Fuel lines must be properly installed, properly fastened and free of leaks. There must be no possibility of gasoline vapors entering vehicle interior.
 - You are required to install an approved, flexible, non-conductive fuel line between the generator fuel connection point and rigid fuel lines.
- ▲ If the generator can be equipped with a liquid propane (LP) gas fuel system, install the unit so it complies with all codes, standards and regulations pertaining to such systems. LP gas is highly explosive. The gas tends to settle in low areas where even the slightest spark can ignite it and cause an explosion. Do not allow gas vapors to enter the vehicle.
 - Engine exhaust gases contain **DEADLY** carbon monoxide gas. This dangerous gas, if breathed in sufficient concentrations, can cause unconsciousness or even death. Install the exhaust system in strict compliance with applicable codes, standards and regulations. There must be no possibility for exhaust gases entering the vehicle interior and endangering people or animals.

- ▲ The generator set produces dangerously high electrical voltage. Contact with bare wires, bare terminals, etc., will result in extremely hazardous and possibly lethal electrical shock.
 - All applicable electrical codes, standards and regulations must be strictly complied with in the installation and use of this equipment.
 - The generator must be properly grounded (bonded) to the vehicle chassis or frame.
- ▲ If the vehicle electrical circuits can be powered by any other source of electricity (such as a "dockside" power receptacle), there must be no possibility of connecting the different power sources to the vehicle circuits at the same time. The "dockside" (utility) power source must be positively isolated from the vehicle circuits whenever the generator is operating. Failure to isolate the vehicle circuits from the dockside power supply when the generator is running may result in damage to the generator or serious injury or death to dockside (utility) power workers due to backfeed of electrical energy.
 - Never work on the equipment while standing in water, while barefoot, or while hands or feet are wet. Dangerous electrical shock will result.
 - Jewelry conducts electricity, which can cause dangerous electrical shock. Remove all jewelry (such as rings, watches, or bracelets) before working on this equipment.
- ▲ The generator requires an adequate flow of air for cooling and ventilation. Without sufficient cooling air flow, the engine-generator quickly overheats, which causes serious damage to the generator, a fire or an explosion. Generator air inlet and outlet openings must be provided in strict compliance with the manufacturer's recommendations.
 - Never work on this equipment while physically or mentally fatigued. Stay alert at all times.
- ▲ Storage batteries give off **EXPLOSIVE** hydrogen gas while charging. The battery used for cranking and starting this generator should be installed in its own vented compartment. Provide adequate ventilation for the battery, to prevent explosive hydrogen gas from accumulating.
- ▲ Never insert any tool or other object through openings in the generator interior, even if the unit is not running. You might seriously injure yourself or damage the equipment.
 - Staying alert and using "common sense" are major measures for preventing accidents.

GENERAL INSTALLATION INFORMATION

PURPOSE AND SCOPE OF MANUAL

These Installation Instructions have been prepared especially for the purpose of familiarizing installers and owners of the applicable equipment with the product's installation requirements. Give serious consideration to all information and instructions in the Manual, both for safety and for continued reliable operation of the equipment.

Because of the different recreational vehicle models and the variations between the models, it would be extremely difficult, if not impractical, to provide detailed instructions on every installation possibility. For that reason, instructions and illustrations in this manual are general in nature. Illustrations are not intended to serve as detailed installation blueprints.

The installation should comply strictly with all applicable codes, standards and regulations pertaining to the installation and use of this product. If any portion of this manual appears to be in conflict with such codes, standards or regulations, the applicable codes, standards or regulations must take precedence over the manual.

SAFETY

Before handling, installing, operating or servicing this equipment, be sure to read carefully the "Notice to Installer" and "Safety Rules" at front of this manual. Comply with all SAFETY RULES to prevent death, personal injury or damage to equipment and/or property. Stress safety to all installers, operators and service technicians who work on this equipment.

STANDARDS BOOKLETS

Installation, use and servicing of this equipment should comply strictly with published standards, as well as the manufacturer's recommendations. The following standards booklets (latest revision) are available from the sources indicated:

1. NFPA Standard 501C, "Standard for Recreational Vehicles", available from the National Fire Protection Association, Batterymarch Park, Quincy, MA 02269.
2. NFPA 70, "NFPA Handbook of the National Electric Code", obtained from same address as Item 1.
3. ANSI C1-1975 and ANSI 119.2-1975, available from the American National Standards Institute, 1430 Broadway, New York, NY 10018.
4. ANSI A119.2/NFPA 501C, available from the Recreational Vehicle Association, 1896 Preston White Drive, Reston, VA 22090.

5. California Administrative Code, Title 25, available from the State of California, Documents Section, P.O. Box 1015, North Highlands, CA 95660.

6. CSA Electrical Bulletin 946, available from the Canadian Standards Association, Housing and Constructions Materials Section, 178 Rexdale Boulevard, Rexdale, Ontario, Canada, M9W 1R3.

EQUIPMENT DESCRIPTION

Instructions and information in this section pertain to Generac Impact air-cooled generators — more specifically, the installation of Impact 36G recreational vehicle generators. These generators are designed specifically for installing in recreational vehicles.

ENGINE GENERATOR OPERATING SPEED

The generators are driven by gasoline-powered, single-cylinder engines. The engines drive revolving fields (rotors), high frequency, permanent magnet alternators. The generators supply 120 volts AC at 60 Hertz. The generators revolving fields are driven at a variable speed depending on the demand for power. Computers monitor that demand and adjust the engine speed to provide adequate power to the connected loads.

GENERATOR AC CONNECTION SYSTEM

The generators are equipped with single voltage AC connection systems. The following facts pertain to such a connection system:

- On the Impact units, the 120 volts, connections system is protected by a circuit breaker.
- The AC connection system on all air-cooled Impact generators uses a GROUNDED neutral.
- A separate green ground wire is connected to the recreational vehicle's junction box.

LOCATION AND SUPPORT

GENERATOR LOCATION

The most desirable location for the generator set is between the vehicle's main frame members. However, this is seldom possible. Most units must be installed on the side of the vehicle and are difficult to reinforce.

Many recreational vehicles have been factory equipped with an area for the generator set. Some vehicles may even have a generator compartment, provided by the vehicle manufacturer.

Plan the generator location based on the following:

- The generator set must be installed on a framework that is part of the recreational vehicle, as outlined in the paragraph entitled "Generator Support."
- The location must provide an access opening that is large enough to permit generator removal (unless the generator is to be removed from underneath the supporting framework).
- The location must provide easy access to frequently serviced components, such as filters, oil drains, spark plugs and other common maintenance parts.
- The location must provide sufficient room to allow minimum clearance of at least 1 inch between all sides and 1-1/2 inches on top of the generator. If sound insulation is to be used on compartment walls and ceiling, the minimum recommended applies to the space between the generator and such insulation.
- The location must provide adequate cooling and ventilating air flow for the generator without a great deal of work and expense.

GENERATOR SUPPORT

The generator must be securely attached to a metal framework that has been made part of the vehicle frame structure by bolting or welding. The metal framework on which the generator will rest and which will restrain the generator set should consist of at least two horizontal beams. These beams should consist of (a) 1-1/2 inch square, 11 gauge steel tubing OR (b) 1-1/2 inch, 11 gauge angle iron. A typical supporting frame with horizontal support tubing, is shown in Figure 13.

The generator can be installed so that it sits on top of the horizontal support tubing, if the vehicle design permits. Another method is to suspend the generator below the horizontal support tubing by means of suitable, structurally sound metal framework. The following general rules apply:

- Vehicle construction **MUST** be capable of supporting the weight of the generator.
- Whether the generator is mounted above the horizontal support tubing or suspended below the tubing, the supporting frame used must be structurally sound.
- If the generator cannot be bolted directly to the supporting frame or support tubing, consider using additional tubing, angle brackets or other supports to give the supporting frame sufficient strength.

Figure 13 — Typical Horizontal Support Frame

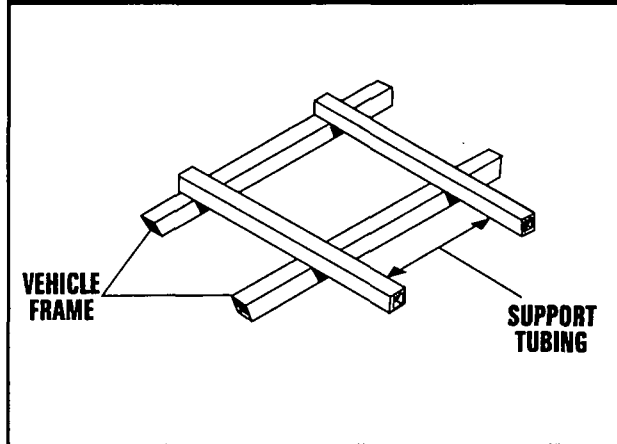

SUSPENDED MOUNTING

If you are going to suspend the generator below the horizontal support tubing, the suspension method you use with the vehicle frame members must have the following: (a) be able to support the weight of the generator; and (b) provide sufficient restraint for the generator. One typical suspended mounting system is shown in Figure 14. The location of a suspended mounting system must be carefully planned, keeping the following general rules in mind:

- Protect the generator against road splash and debris. Baffles or splash guards may be required to protect certain areas of the generator. To make sure the generator is adequately protected, road test the installation through mud, water and slush.

Figure 14 — Typical Suspended Mounting System

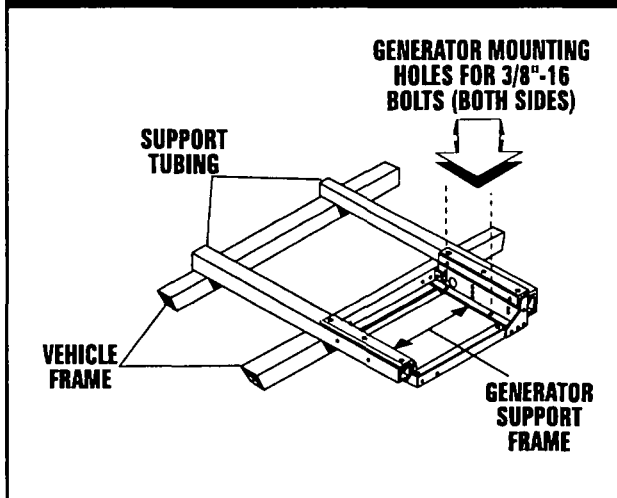

- The installer must make certain that selected location will permit adequate cooling and ventilating air flow to be supplied.

GENERATOR RESTRAINT

Use four 3/8"-16 hardened steel bolts (Grade 5) to fasten the generator to the supporting frame or the support tubing. These bolts must pass through (a) the generator mounting base, (b) the compartment floor, if a compartment is used, and (c) the supporting framework (Figure 15). All bolts must be long enough so that when tight, at least 3 threads are visible past the retaining lock nuts. Refer to "COMPARTMENT" section for location of generator mounting holes.

Figure 15.— Typical Generator Restraint

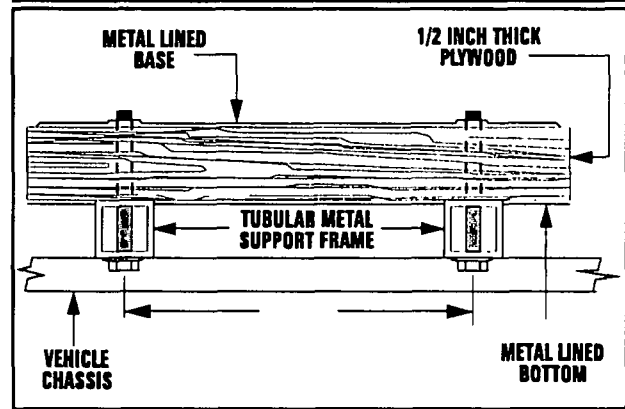

GENERATOR COMPARTMENTS

COMPARTMENTS

The generator set may or may not be installed inside a compartment that is constructed specifically for housing a generator. This section applies to generator compartments when they are installed. The following general rules apply to compartments:

- The generator compartment should be either constructed of, or lined with, 26 gauge galvanized steel.

IMPORTANT: ALUMINUM IS NOT AN ACCEPTABLE ALTERNATIVE TO GALVANIZED STEEL, DUE TO ALUMINUM'S LOW MELTING POINT.

- If the compartment is lined with galvanized steel, it may be constructed of any material. Generac recommends that the compartment be constructed of 1/2-inch thick plywood, with the floor made of a double thickness of plywood for added strength.
- All seams, splices and joints of the compartment walls (unless vapor tight by design) should be caulked.

IMPORTANT: CAULKING MUST BE DONE SO THAT THE CAULKING MATERIAL WILL STAY IN PLACE PERMANENTLY. PRESSING SUCH MATERIALS AS PUTTY TAPE ONTO JOINTS AND SEAMS WILL NOT MEET THAT REQUIREMENT. A HIGH QUALITY SILICONE RUBBER SEALANT IS RECOMMENDED.

- Holes and openings through the compartment walls for passage of electrical conduit, conductors, etc, into vehicle living area must be sealed vapor-tight with silicone rubber base sealant.
- If you use flexible metal conduit, seal the conduit at the end where it terminates inside the junction box. Flexible metal conduit is NOT vapor tight along its entire length.
- Seams and joints of the galvanized steel (whether used as a liner or the compartment itself) must be lapped and mechanically secured. Such seams may be manufactured, welded, bolted, riveted, or screwed. Manufactured lock seams are shown in Figure 16.

Figure 16 — Types of Lock Seams

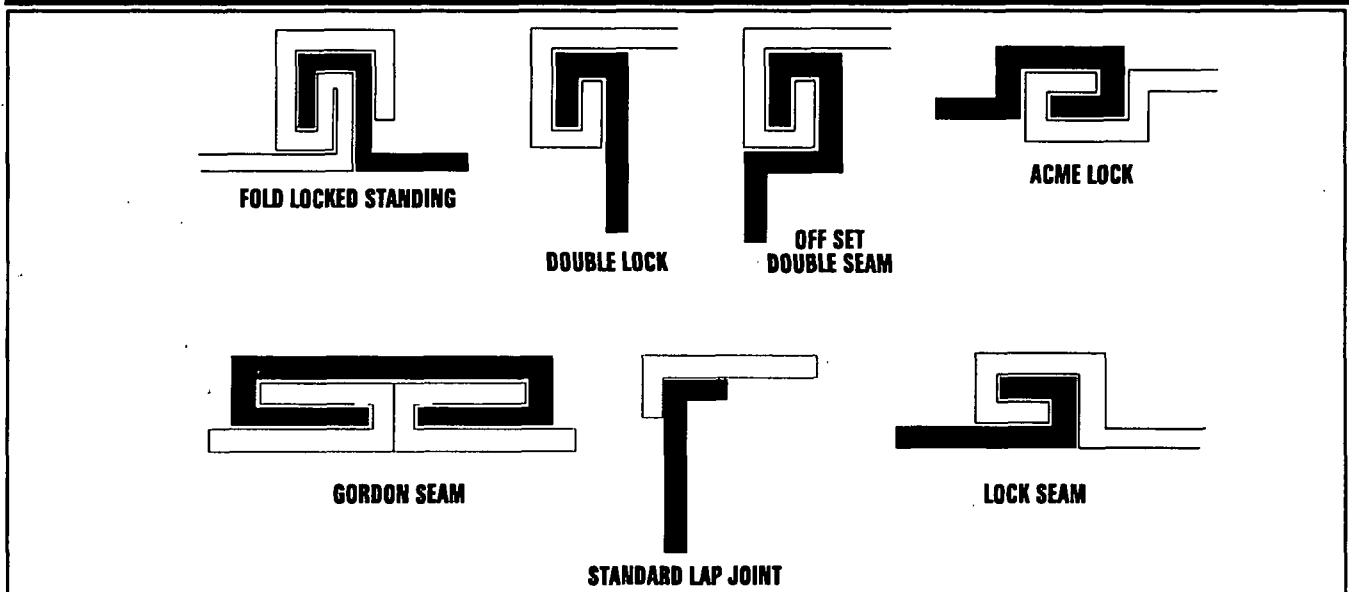

COMPARTMENT SIZE

Plan the compartment size carefully. Provide a minimum of at least 1 inch (2" recommended) of clearance between the generator and compartment walls and 1 inch (2" recommended) of clearance between the generator and the ceiling AFTER you have lined the compartment with metal, and AFTER you have installed sound insulation (Figure 17).

NOTE: Refer to the "Major Features and Dimensions" drawing in the back of this manual.

Figure 17 — Provide Clearance Around Generator

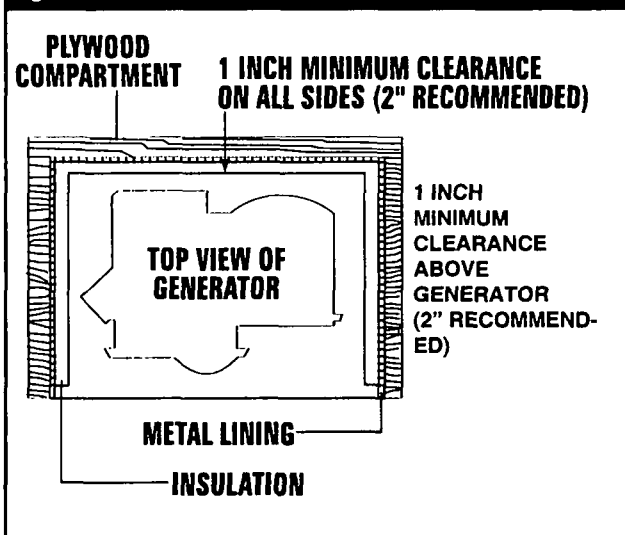

COMPARTMENT CONSTRUCTION

- The generator compartment should be constructed of 1/2 inch thick plywood. Make the compartment floor a double thickness of 1/2 inch plywood with the grain of the wood at cross section for added strength (Figure 18).

Figure 18 — Typical Compartment Construction

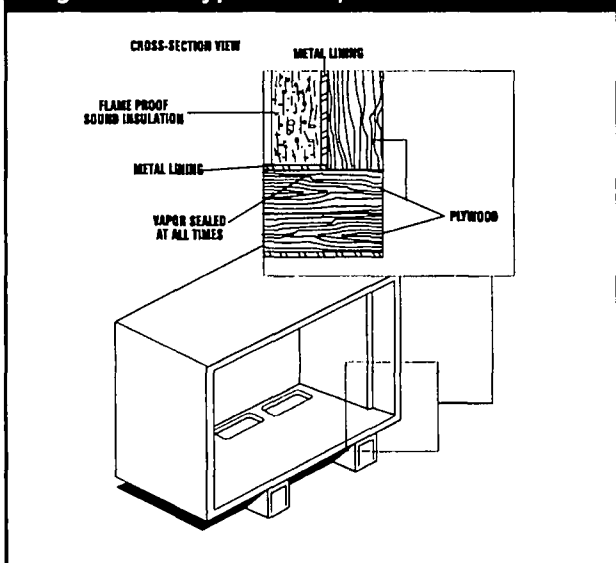

- Line the entire compartment interior with 26 gauge galvanized steel as described above.
- Line the exterior (underside) of the compartment floor with 26 gauge galvanized steel.
- Vapor seal all compartment seams and joints, to prevent poisonous, flammable or explosive vapors from entering the vehicle interior. Refer to the sealant information as noted previously.

NOTE: Silicone rubber base sealant is an acceptable caulking material. Pressing putty tape onto compartment joints and seams is NOT acceptable.

- After the compartment has been metal lined and vapor sealed, line the compartment interior walls and ceiling with an approved, non-flammable sound insulating material. See "Sound Insulating Materials."



DANGER: Do not install sound insulation or any absorbent material on the compartment floor interior. Such materials will become soaked with combustible or explosive vapors and liquids and will become a fire hazard.

- Openings in compartment walls for passage of electrical conduit, conductors, hoses, cables, etc., must be made vapor tight with suitable caulking material.
- Flexible conduit must be sealed internally at the end where it terminates inside a compartment's electrical junction box.

NOTE: The preceding is required because flexible conduit, due to its unique construction, is not vapor-tight along its entire length.



DANGER: Do not install any flammable material directly above or around the compartment. Heat, transferred through the compartment structure, may be sufficient to ignite, char or discolor seat cushions, fiberboard and other flammable materials. You may need to use approved non-flammable insulating materials in high temperature areas.

SOUND INSULATING MATERIALS

Once installers have determined that compartments are properly constructed and metal lined, they can add acoustical material. This may include additional sealant or insulating material, to reflect noise away from the vehicle interior.

Sound insulating materials should be of a non-flammable type. One excellent insulating material is a 1 inch thick fiberglass having a 2-pound density. When fiberglass is used, its coated side should face toward the compartment interior.

Using a combination of sound insulating materials can often reduce noise more effectively than a single material. For example, a sheet of lead or visco-elastic material, along with a layer of other acoustical material, is more effective than when a single material is used.

COMPARTMENT FLOOR CUTOUTS

You must provide openings in the generator compartment for the following items (Figure 19):

- Engine exhaust and cooling air outlets
- Generator cooling air inlet
- Four holes for passage of generator mounting bolts. See "Generator Restraint" on Page 17.



DANGER: Fuel lines and exhaust piping must not penetrate into vehicle living area.

ACOUSTICS

If excessive noise levels should become a problem, the installer may wish to consider the following:

- Using special sound insulating materials.
- Construction of a special noise abatement compartment.

IMPORTANT: ANY METHOD USED TO REDUCE NOISE MUST NOT ADVERSELY AFFECT THE FLOW OF COOLING AND VENTILATING AIR INTO OR OUT OF THE COMPARTMENT.

In addition to the effective use of sound insulating materials, construction of a special noise abatement compartment might be considered to reduce noise levels. Such a compartment might be constructed as follows (Figure 20):

- Use 5/8-inch thick or 3/4-inch thick plywood in the compartment.
- Construct the compartment floor of a double thickness of 5/8-inch or 3/4-inch plywood.
- Line the compartment interior walls and floor, as well as the underside of the floor, with 26-gauge galvanized steel.
- Vapor seal all compartment seams and joints.

- Over the galvanized steel lining, install a selected combination of acoustical materials as mentioned in "Sound Insulating Materials."

Figure 20 — Typical Noise Abatement Compartment

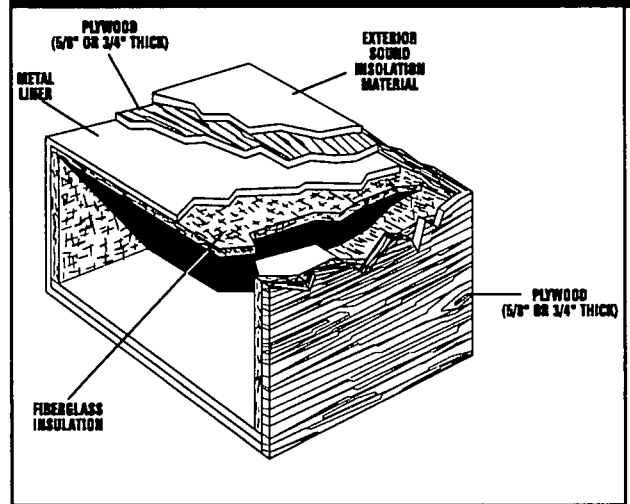

DANGER: Do not install any insulation or other absorbent materials on the interior or underside of the compartment floor.

- Seal all compartment door edges to prevent noise leakage around the door perimeter.
- Line the compartment door interior (except for air openings) with suitable, fire proof sound insulation (such as 1-inch thick fiberglass with a 2-pound density).

Figure 19 — Compartment Floor Cutout

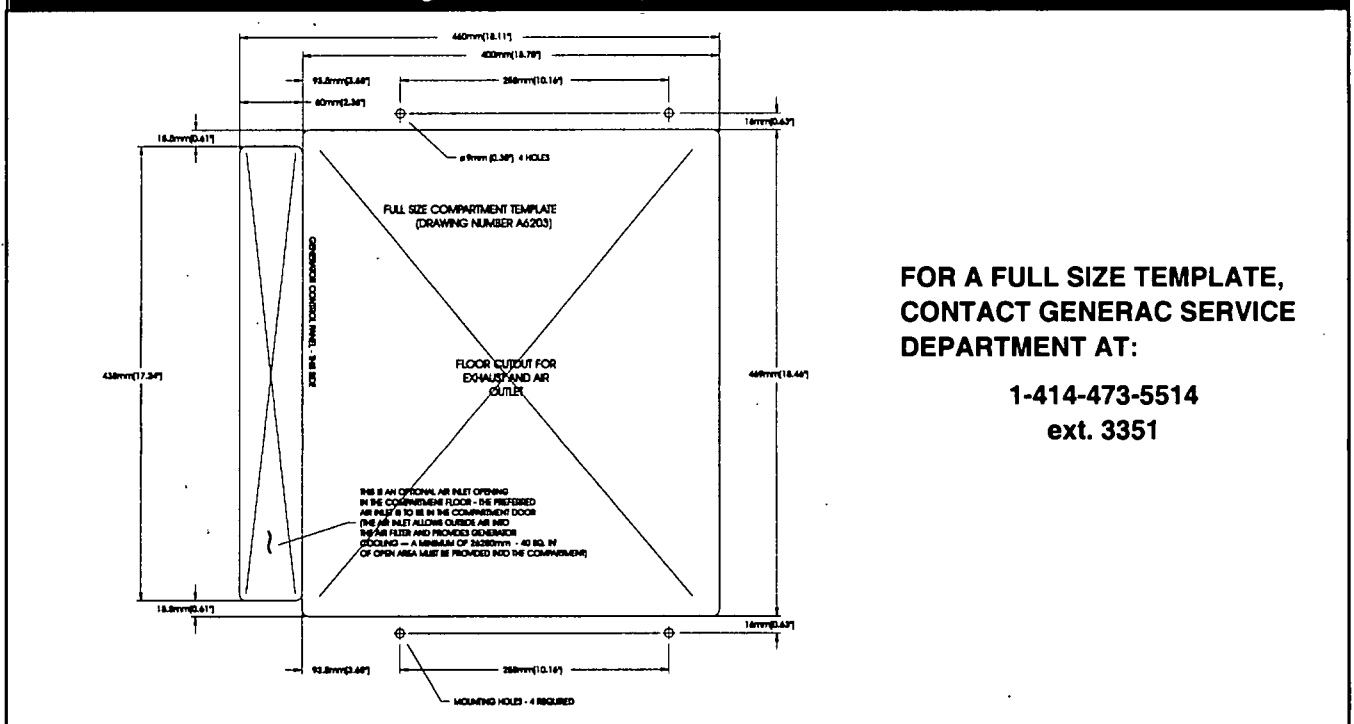

COOLING AND VENTILATING AIR

It is absolutely essential that an adequate flow of air for cooling, ventilating and engine combustion be supplied to the generator set. Without sufficient air flow, the engine-generator quickly overheats. Such overheating can cause serious operating difficulties and may also cause fire and personal injury. The installer must make sure that sufficient air is available to the generator for cooling, ventilating and combustion. The installer must also provide for a path for exhausting the cooling air to the exterior of a compartment, if so equipped.



DANGER: Never use discharged cooling air for heating or permit such air to enter the vehicle interior. This air contains deadly carbon monoxide gas and other poisonous, flammable or explosive gases.

GENERATOR AIR FLOW

Engine operation drives cooling fans for the 2-stage cooling air system. A pressure fan draws cooling air into the top of generator and into the side of the control panel (Figure 21). This air flow cools the engine-generator and electronic components. The second part of cooling system, a suction fan, draws air that is heated from a hot engine into a collector pan at the base of the unit. This heated air (although cooler than exhaust muffler) is directed across the muffler to cool it. The heated air flow is then deflected out the bottom toward the ground.

Figure 21 — Air Flow Through Engine-Generator

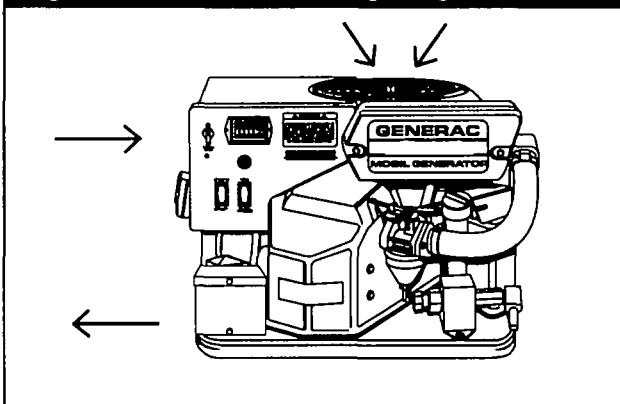

COOLING AIR INLET OPENINGS

Ideally, you should provide three air inlet openings, whether the generator is housed in a conventional compartment or not. Two of the openings should be 10 square inches and located as shown in Figure 22. The third opening should provide for a minimum of 40 square inches unrestricted and be located lower on the compartment door.

NOTE: Screening, louvers, or expanded metal that cover air openings restrict air flow that you must compensate for by making the actual air opening proportionately larger. See "Compensating for Restrictions."

For conventional compartment mounted units, the air inlet is generally provided in the compartment door.

Figure 22 — Air Inlet in Compartment Door

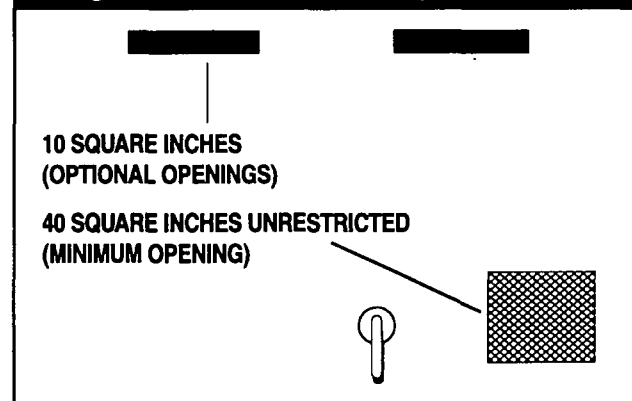

IMPORTANT: IF YOU PLAN TO INSTALL THE GENERATOR IN A COMPARTMENT, BE SURE TO LEAVE AT LEAST ONE INCH (2" RECOMMENDED) OF CLEARANCE BETWEEN THE GENERATOR AND COMPARTMENT WALLS AND CEILING. INCLUDE 26 GAUGE GALVANIZED STEEL LINING AND SOUND INSULATION WHEN YOU MEASURE FOR THIS 1 INCH (2" RECOMMENDED) CLEARANCE.

When the unit is installed on a suspended mounting system, one of several different methods of supplying air flow may be used as follows:

- Provide a door in the vehicle skirt having an air inlet opening (Figure 23).

Figure 23 — Suspended Mount Inlet Door

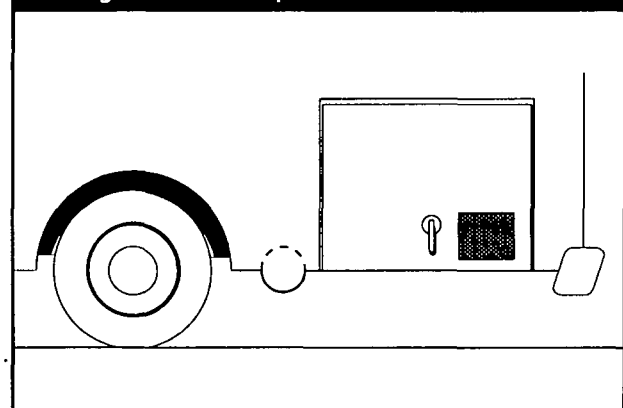

- Using ductwork (Figure 24 on Page 21). The installer must be sure air is available to the top of the generator since air inlets are located at the top.
- By providing an opening in the vehicle skirt and space above the generator for cooling air flow (Figure 25 on Page 21). Recommended clearance above the top of the generator is at least 2 inches.

Figure 24 — Air Inlet Using Ductwork

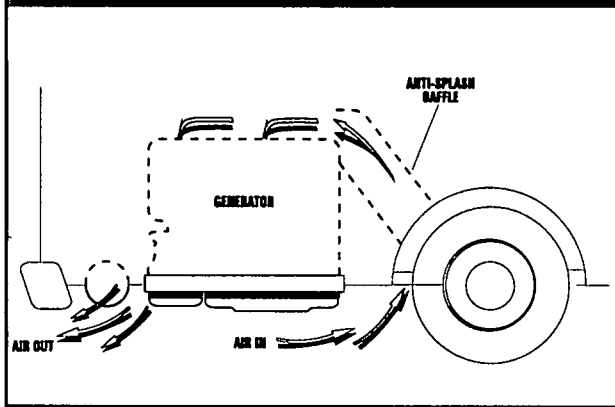
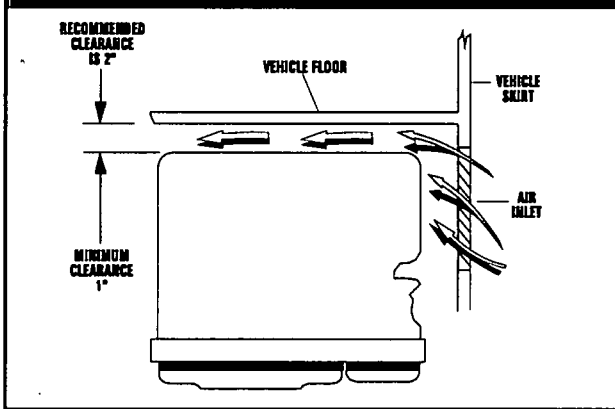

Figure 25 — Air Inlet in Vehicle Skirt



COMPENSATING FOR RESTRICTIONS

Such materials as screening, louvers, or expanded metal can restrict the free flow of air. Compensate for this restriction by making the actual air opening proportionately larger.

Some materials may offer only a 60 percent "free air inlet area." Other more efficient materials may provide up to a 90 percent free air inlet area. The percentage of free air inlet opening is usually available from the material supplier or manufacturer.

TO DETERMINE THE ACTUAL AIR INLET OPENING SIZE REQUIRED, DIVIDE 40 SQUARE INCHES BY THE PERCENTAGE OF FREE AIR INLET AREA FOR THE MATERIAL YOU WILL USE.

For example: If you plan to use screening with an 80% free air inlet area, divide 40 by 0.8, which results in 50 square inches. Minimum actual size of air inlet opening in this case is 50 square inches. An opening that measures 4 inches wide by 12-1/2 inches long provides the required air flow ($4 \times 12.5 = 50$ square inches).

TESTING THE INSTALLATION

Generac recommends testing the installation to be sure adequate cooling air flow is available to the unit before placing the unit into service. If the unit shows signs of overheating, you will need to enlarge the air openings. Never place a unit into service until absolutely certain that cooling and ventilation is adequate.

IMPORTANT: YOU MUST TEST THE INSTALLATION ESPECIALLY IF YOU BRING IN AIR FROM BELOW THE GENERATOR SET.

GASOLINE FUEL SYSTEM

Installing a gasoline fuel system (Figure 26) for recreational vehicle generator sets must comply with applicable codes, standards and regulations. The entire fuel system must be completely free of leaks. There must be no possibility of gasoline vapors entering the vehicle interior.

Figure 26 — Generator Fuel System

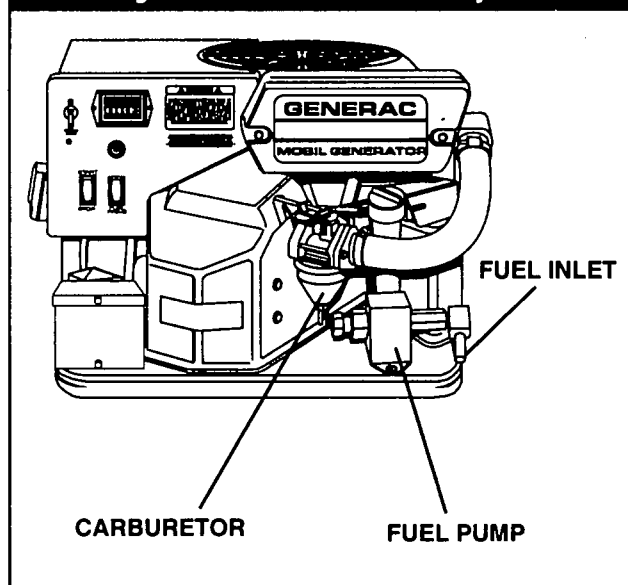

DANGER: Gasoline is highly flammable and its vapors are explosive. Comply with all codes, standards and regulations pertaining to gasoline fuel systems used in mobile generators. Properly install and maintain the fuel system and keep it entirely free of leaks. Gasoline vapors must not enter the vehicle interior.

Factory installed generator fuel system components include (a) fuel filter, (b) 12-volt DC electric pump, (c) engine carburetor, and (d) interconnecting lines and fittings. Connect a fuel supply line to the fuel filter inlet. Use a flexible length of approved fuel hose between the fuel filter inlet connection and rigid fuel lines.

FUEL TANK

Either the generator must share the vehicle engine's fuel tank, or you must install a separate fuel tank for the generator set. All fuel tanks installed on the vehicle must be constructed, installed, restrained so it complies with applicable codes, standards and regulations.

If the generator is to share the vehicle engine's tank, separate fuel pickup tubes are required for the engine and the generator. Generac recommends that you make the fuel pickup tube 2 to 3 inches shorter than the vehicle engine's pickup tube. This prevents the generator from depleting the entire fuel supply during prolonged generator operating periods.



CAUTION: Do NOT tee the generator fuel supply line into the vehicle engine fuel supply line. If this is done, the generator will be starved of fuel when both engines are operating at the same time. Also, while the vehicle engine is not running, generator operation may drain the vehicle engine supply line, making it difficult to start the vehicle engine.

GENERATOR FUEL SUPPLY LINE

■ RIGID FUEL LINES

Those lines used to supply fuel from a tank to the generator must comply with applicable codes, standards and regulations. The following generator rules apply to rigid fuel lines:

- Rigid lines should be of annealed, seamless, drawn aluminum or steel.
- Lines and fittings must comply with SAE J512F, "Standard Automotive Fittings", or with ANSI B126.26 (latest edition).
- Route the fuel line so that at least 2 inches of clearance is maintained between the line and any exhaust system parts.
- Do not attach electrical wiring to fuel lines. Route the wiring so it cannot come into contact with any fuel line.
- Route fuel lines so if they leak, fuel does not drip onto any electrical or exhaust system parts.
- Use non-ferrous metal straps without sharp edges to secure fuel lines.

■ FLEXIBLE FUEL LINE

Use an approved flexible length of fuel hose between the generator fuel inlet connection and rigid fuel lines. This prevents breaking of the line caused by vibration, shifting, settling or movement. The following rules apply:

- The flexible hose must comply with SAE J30B, "Standard for Fuel and Oil Hose". It must be approved for use with gasoline.
- The hose should be at least 6 inches longer than is needed to prevent the hose from rupturing if the generator shifts or settles.

EXHAUST SYSTEM

The generator exhaust system must be safely and properly installed. Only approved mufflers and other exhaust system parts must be used. A properly installed exhaust system must be vapor tight, quiet and completely safe.



CAUTION: Never tee the generator engine exhaust pipe into the vehicle engine exhaust piping. This causes excessive back pressure on the generator engine. Also, water from one engine can damage the other engine.



DANGER: The generator engine gives off deadly carbon monoxide gas through its exhaust system. This dangerous gas, if breathed in sufficient concentrations, can cause unconsciousness or even death. Symptoms of carbon monoxide poisoning are (a) inability to think coherently, (b) vomiting, (c) twitching muscles, (d) throbbing in temples, (e) dizziness, (f) headache, (g) weakness and sleepiness. If any of these symptoms are experienced, move into fresh air immediately. If symptoms persist, get medical attention. Do not operate the generator until its exhaust system has been inspected and repaired.

MUFFLERS AND SPARK ARRESTORS

Exhaust mufflers and spark arrestors that Generac supplies meet code and standard requirements, and are approved by the U.S. Forest Service. Use only mufflers and parts approved by Generac. Any person(s) installing an unapproved muffler, or an unapproved exhaust system part, or modifying an exhaust system in any way that might cause a hazard, is liable for any damage, injury or warranty expense that might be caused by such unapproved installation or modification.

Failure to provide and maintain a spark arrestor may be in violation of the law. If this generator is used on any forest covered, brush covered, or grass covered unimproved land, you must provide a spark arrestor. The vehicle owner or operator must maintain this device in good condition. In the State of California, the preceding is required by law (Section 4442 of the California Public Resources Code). Other states may have similar laws. Federal laws apply on federal lands.

TYPE OF EXHAUST SYSTEM

The Impact-36G generator has a configuration for a bottom out exhaust system and is equipped with such an exhaust muffler (Figure 27).

EXHAUST SYSTEM SAFETY

- Maintain a clearance of at least 3 inches (76mm) between exhaust system parts and any combustible material (such as wood, felt, cotton, organic fibers or other like material). If you cannot maintain the 3-inch clearance, locate, insulate or shield the exhaust part(s) so that the temperature of any combustible material is not raised more than 117°F (65°C) above the ambient air temperature.
- Extend the exhaust system at least one inch (25mm) past the outer edge of the vehicle. Do not terminate the exhaust system under the vehicle.
- Terminate the exhaust tailpipe such that exhaust gases will not be drawn back into the generator compartment and recirculated.
- If there is any possibility of the tailpipe or muffler being damaged, protect these damage prone areas by means of a protective device (such as a "skid bar").
- Install the generator exhaust system according to safe automotive practices.
- Use enough exhaust system hangers to prevent any part of the system from being dislocated.
- Use exhaust system parts recommended by Generac. Using unapproved exhaust mufflers and exhaust system parts is the responsibility of the person(s) installing such unauthorized parts.
- Do not terminate the exhaust system under any opening, window or vent which can be opened or is not permanently sealed from the vehicle interior.
- Exhaust piping must be large enough to prevent excessive back pressure on the generator engine.
- Never tee the generator engine exhaust pipe into the vehicle engine exhaust piping. This causes excessive back pressure on the generator engine. Also, water from one engine can damage the other engine.
- Plan exhaust system installation carefully. Comply with all applicable codes, standards and regulations.

Figure 27 — Exhaust System

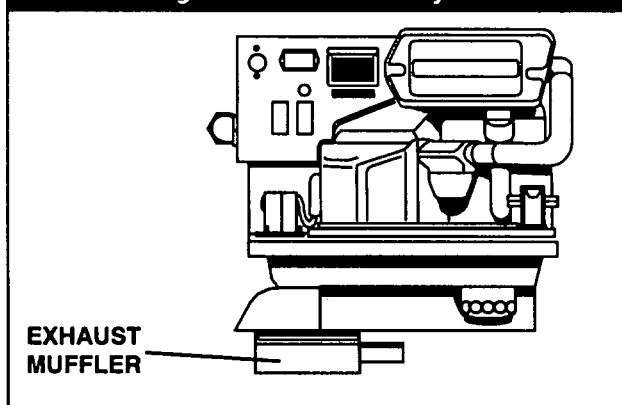

ELECTRICAL CONNECTIONS

Be sure to read "Generator AC Connection System" on Page 4.

The following general rules apply to electrical connections in a recreational vehicle:

- Qualified electricians who are familiar with applicable codes, standards and regulations should install electrical wiring.
- The wiring should comply with codes, standards and regulations. The National Electric Code (NFPA 70), as well as state and local codes, apply.
- Switches and circuit breakers should be of a type approved for use in recreational vehicles and must be mounted and installed to prevent damage from road shock.
- Wiring must be of adequate size, with approved insulative qualities, and properly supported.
- Conduit and wire openings into generator compartment (if used) must be vapor-sealed, to prevent entry of flammable, explosive or poisonous gases into the vehicle.

ELECTRICAL JUNCTION BOX

Install an approved, square electrical junction box that has a blank cover on the interior or exterior wall of the area you plan to install the generator (NOT on the generator). Route the generator's AC output leads into this junction box through approved flexible conduit, and into this junction box. This is the point of first termination for generator AC output leads.

WIRING

- Wiring should be of stranded copper to reduce chance that vibration may cause breakage.
- Wire gauge size of wires should be large enough to handle at least 115% of the installed generator's rated maximum current.
- If neutral conductors are used, they must be the same size as other leg wires.
- Route power supply conductors from generator AC output leads T1 (black) and T2 (white) and the green ground wire through approved flexible conduit to the electrical junction box on the compartment wall.
- If flexible metal conduit is used between the generator and the compartment junction box, the conduit end that terminates the compartment junction box, must be vapor-sealed. Flexible metal conduit is NOT vapor tight along its entire length.
- From the junction box route power supply wires through approved conduit to either (a) double-pole, double-throw transfer switch, or (b) approved isolation receptacle. Connecting to a transfer switch or isolation receptacle must prevent vehicle electrical circuits from being connected to two different power supplies at the same time (such as generator and dockside power).

- Conductors must be rated 221°F (105°C) or must be of a larger conductor size.

GENERATOR AC CONNECTIONS

Generator AC output leads T1 (black) and T2 (white) come out of the generator as shown in Figure 28. Lead T1 (black) is "hot." Lead T2 (white) is the "neutral" lead and is internally connected to ground. The green lead (0) connects to ground in the junction box of the recreational vehicle.

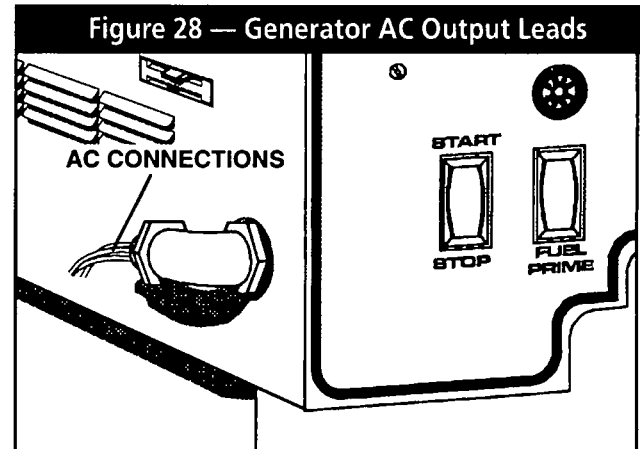

Line T1 (black) is protected against overload by the circuit breaker (CB1). Use line T1-T2 to operate 120 volts, 1-phase, 60 Hz, AC loads.



CAUTION: Do NOT connect electrical loads in excess of any circuit breaker rating or you will develop problems with circuit breaker tripping, which causes a loss of AC output. Also, do NOT exceed the generator's rated wattage capacity. Add the watts or amperes of all lighting, appliance, tool and motor loads the generator will operate at one time. This total should be less than the unit's rated wattage/amperage capacity.

CONDUIT

Route the conductors between the generator and the junction box through approved, flexible conduit. The following general rules apply:

- Cut wiring to the required length and allow extra wire for junction box connections.
- Carefully prepare conduit ends, to prevent sharp edges from cutting through wiring insulation.
- Route conduit so it does not interfere with generator movement.
- If you use metallic conduit, vapor seal the end of the conduit where it enters the junction box. Do this because flexible metallic conduit is not vapor proof along its entire length.

ISOLATING DIFFERENT POWER SOURCES

Conductors from the junction box must terminate in a double pole, double throw transfer switch (Figure 29). An alternate method for isolating different power sources is by using an isolating receptacle (Figure 30 on Page 26). Whichever method you use, you must be certain that both power sources are NOT connected at the same time.

GROUND FAULT CIRCUIT INTERRUPTERS

The National Electric Code (NFPA 70, 551-7) requires that you install ground fault circuit interrupters (GFCIs) on all external and some internal electrical receptacles. Contact your manufacturer or dealer for recommendations.

POWER SUPPLY CORD

The power supply cord must comply with all applicable codes, standards and regulations. It must be large enough to handle the full amperage to which it will be subjected.

Figure 29 — Transfer Switch Isolation Method

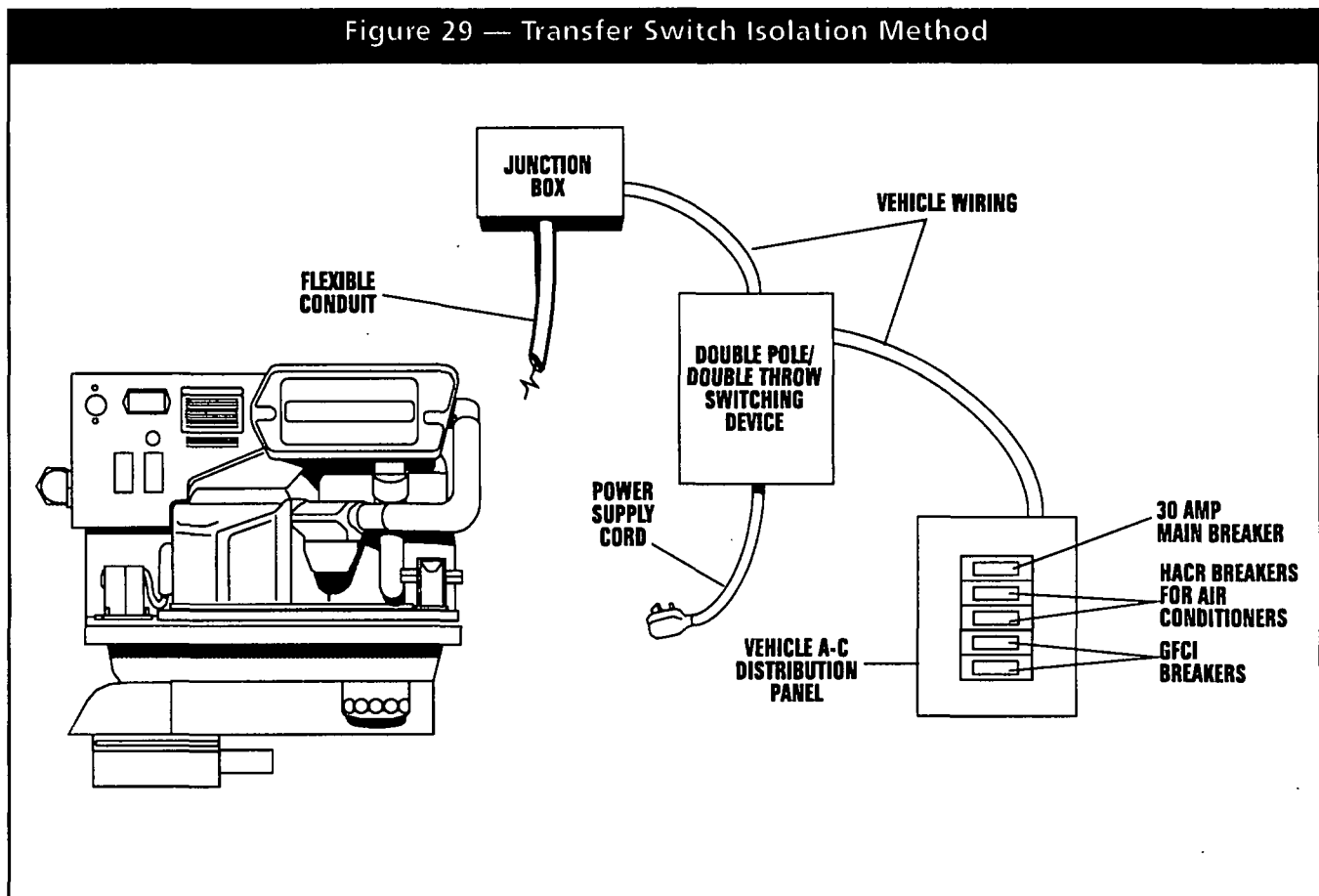
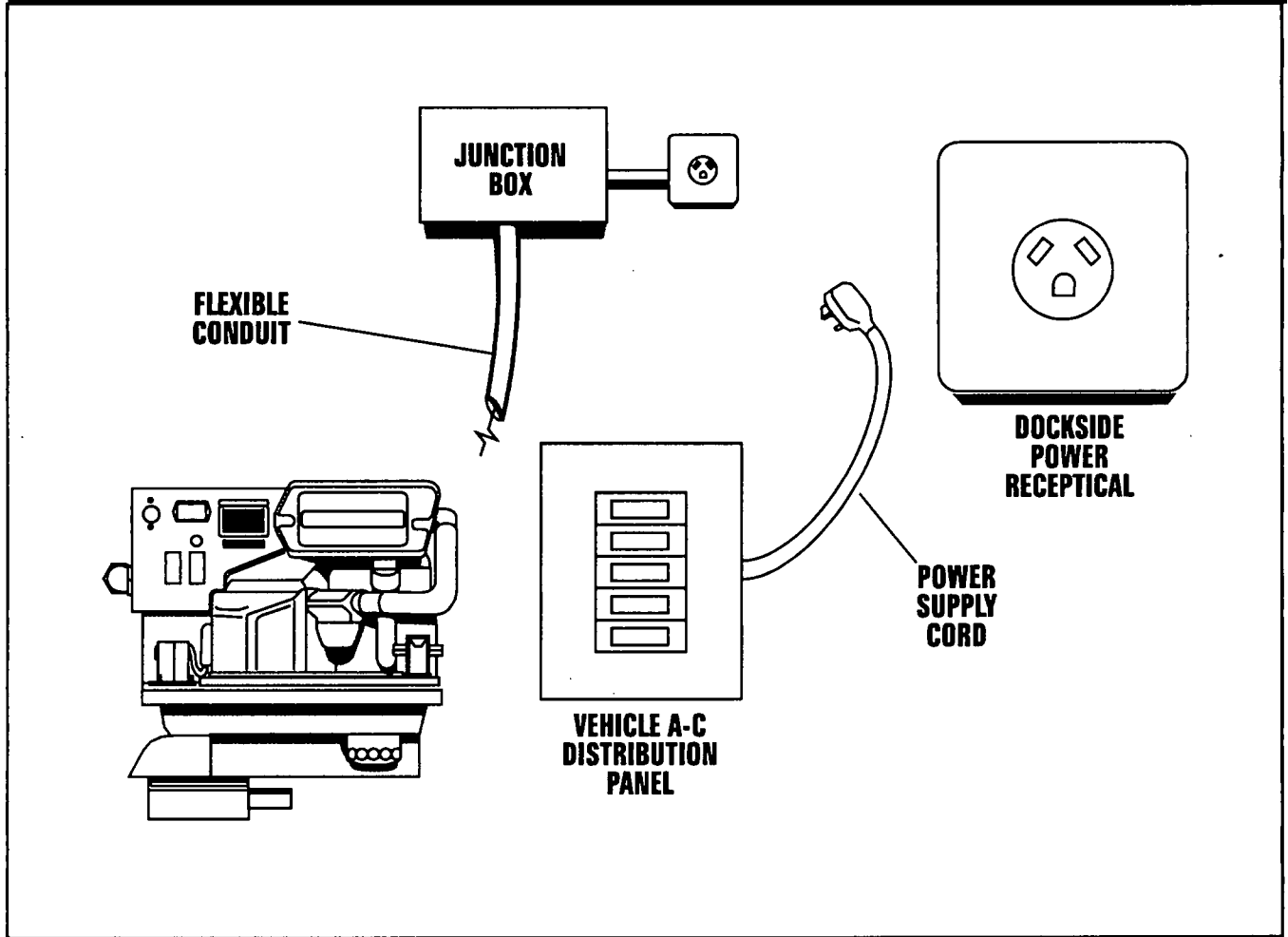

Figure 30 — Installation with Isolation Receptacle



BATTERY INSTALLATION

RECOMMENDED BATTERY

Install a battery that meets the following requirements:

- Battery must be a 12 volt, automotive type storage battery.
- For prevailing ambient temperatures above 32°F (0°C), use a battery rated 70 amp-hours and capable of delivering 360 cold cranking amperes.
- For prevailing ambient temperatures below 32°F (0°C), use a battery rated 95 amp-hours and capable of delivering 450 cold cranking amperes.

IMPORTANT: IF THE BATTERY IS TO BE USED TO POWER OTHER VEHICLE ACCESSORIES, AS WELL AS START THE GENERATOR, YOU MAY NEED A BATTERY WITH A LARGER CAPACITY.

BATTERY CABLES

Using battery cables that are too long or too small in diameter may cause a drop in voltage which causes starting problems. For best cold weather starting, the voltage drop between battery terminals and the generator connection point should not exceed 0.12 volts per 100 amperes of cranking current.

Select battery cables based on (a) cable length, and (b) prevailing ambient temperatures. Generally, the longer the cable and the colder the weather, the larger the cable size must be as shown in the chart below.

CABLE LENGTH In Feet (meters)	CABLE SIZE
0 to 10 (0 to 3)	2*
11 to 15 (3.4 to 4.5)	0
16 to 20 (4.5 to 6)	000

*For warm weather, use No. 2 cable up to 20 feet.

BATTERY CABLE CONNECTIONS

1. Connect the battery cable from the battery post or terminal indicated by a POSITIVE, POS or (+) to the large lug on the starter contactor as indicated in Figure 31.
2. Connect the battery cable from the battery post indicated by a NEGATIVE, NEG or (—) to the frame ground connection (Figure 31).

NOTE: If the generator compartment is grounded to the vehicle chassis, you need not connect a NEGATIVE battery cable to the frame ground on the generator base. Connect the negative cable to the frame ground of the chassis.

3. Connect cables so the connections are clean and tight.

BATTERY COMPARTMENT

Install the generator battery in its own, vented compartment. Place the battery compartment away from any source of heat, sparks or flame.

Provide ventilation openings in the battery compartment. The minimum size of openings should be 2 square inches at the top of the compartment. Mount the battery on a strong, rigid supporting structure, where leaks and spills of battery fluid will not cause damage.

Figure 31 — Connecting Battery Cables

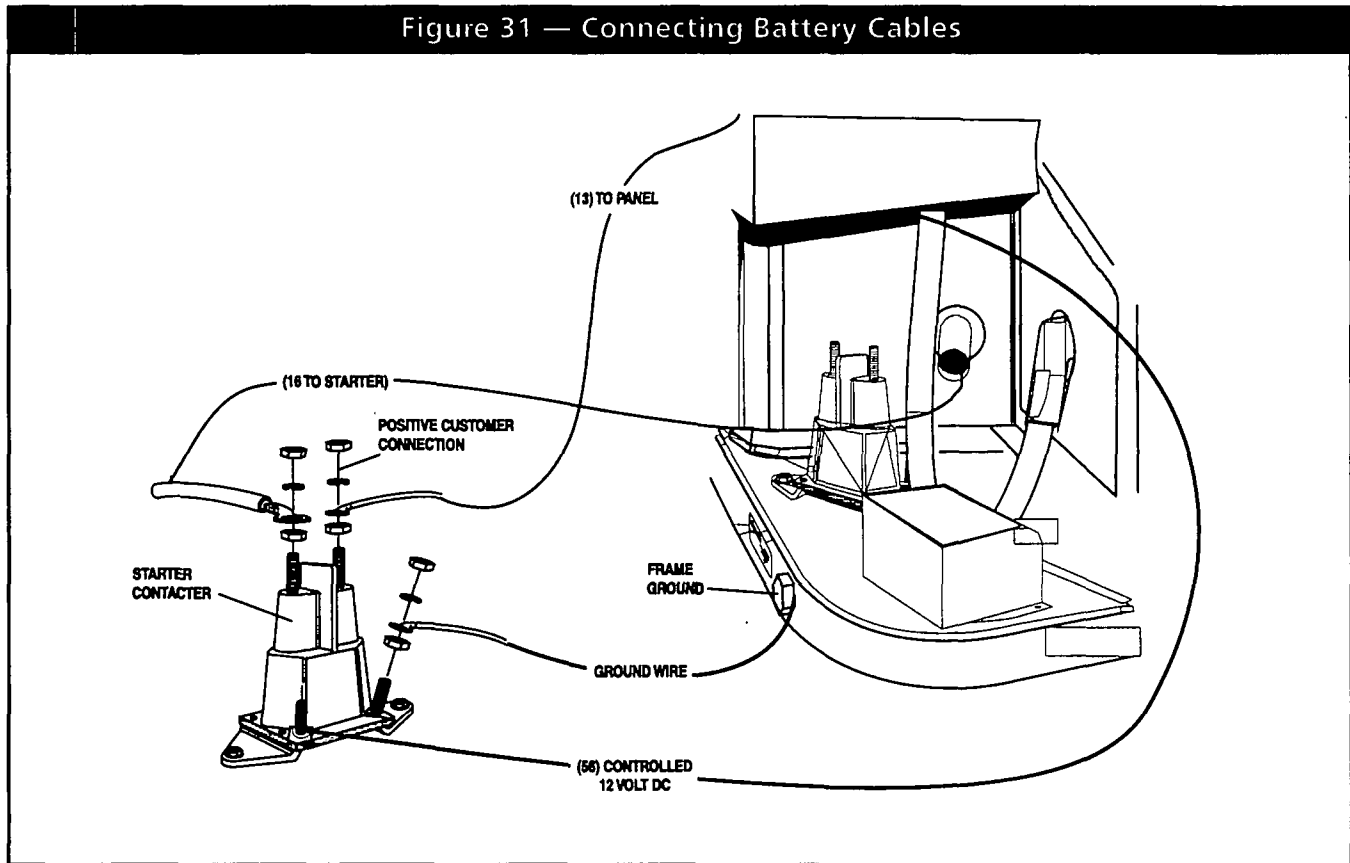

OPTIONAL ACCESSORIES

A plug-in receptacle (Figure 32) is provided on the generator set, near the AC connection wires. Use this receptacle to connect an optional remote-mounted start/stop panel to the generator. Installation of such a panel will permit you to start and stop the generator engine from any convenient location inside the vehicle.

Figure 32 — Remote Panel Plug-In Receptacle

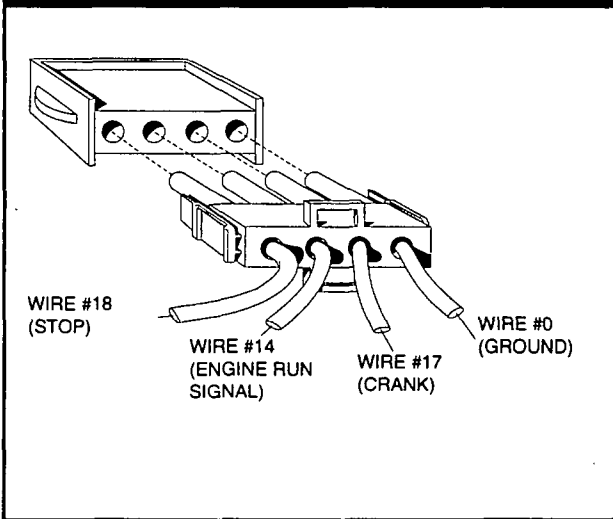

REMOTE PANEL MODELS

Model 9042: This remote panel (Figure 33) mounts a rocker type start/stop switch and a "Generator Run" advisory lamp. The lamp will turn on to indicate the engine is running.

Figure 33 — Model 9042 Remote Panel

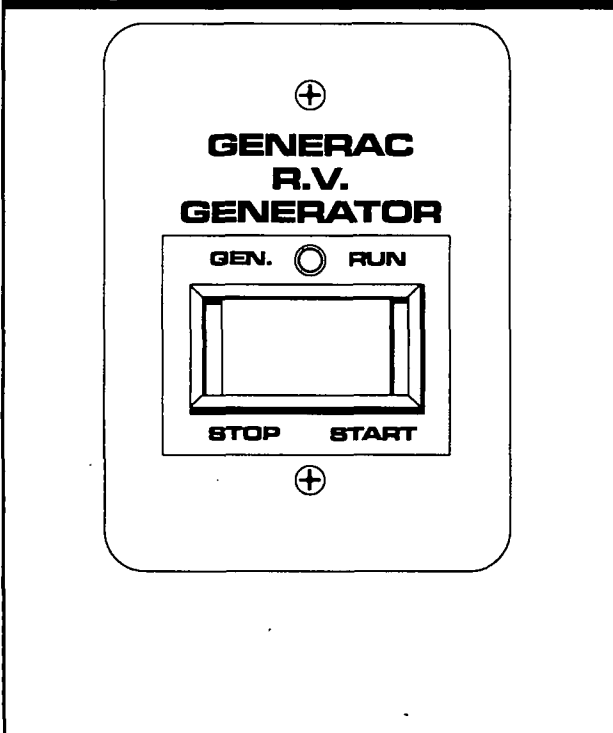

Model 9043: This panel mounts a rocker type switch, a "Generator Run" lamp and an hourmeter (Figure 34). Use the hourmeter in conjunction with the periodic maintenance schedule for your generator.

Figure 34 — Model 9043 Remote Panel

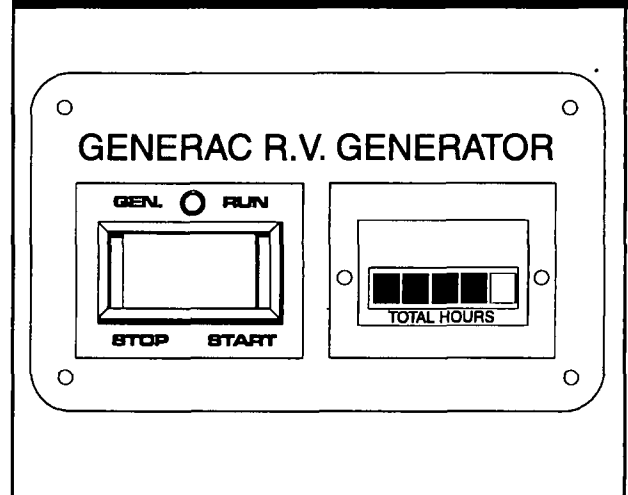

REMOTE PANEL CABLES

Interconnection cables are available from Generac for connecting the optional remote panels to the generator receptacle.

- To order a 10-foot long, 4-wire cable, specify Model 9045.
- To order a 30-foot long, 4-wire cable, specify Model 9046.

POST INSTALLATION TESTS

The air cooled generator set was factory tested and adjusted using gasoline as fuel. You should not be required to adjust the unit any further except under special circumstances.



WARNING: Do not make any unnecessary adjustments. Factory settings are correct for most applications. When making adjustments, however, be careful to avoid overspeeding the engine.

BEFORE INITIAL START UP

Before starting, complete the following:

1. Check engine crankcase oil level and, if necessary, fill to dipstick FULL mark with the recommended oil. Do not fill above FULL mark.
2. Check the fuel supply. Gas fuel lines must have been properly purged and leak tested in accordance with applicable fuel codes. All fuel shutoff valves in the fuel supply lines must be open.



DANGER: If an LP (propane) gas fuel system has been installed, it must have been properly tested for leaks before operating the system in compliance with ANSI 119.2/NFPA 501C. No leakage is permitted. You must be sure no gaseous fuel vapors enter the vehicle interior.

INITIAL START

When absolutely certain that the unit has been properly installed and prepared for use, start the engine as follows:

1. Turn off all electrical loads. Do this by setting the generator main circuit breaker to its "OFF" or "OPEN" position.
2. Refer to the Owner's Manual shipped with unit for cranking and starting instructions. The engine may require more cranking for initial starting since the fuel lines have to be primed (Use of the Primer Switch will shorten this time).

3. Let the engine warm up for about five minutes to allow internal temperatures to stabilize.
4. Carefully inspect the engine-generator for fuel, oil and exhaust system leaks. Before proceeding to the next step, correct any leakage immediately.
5. When all tests and adjustments at no-load are completed, apply electrical loads and check for proper operation under load. See "Testing Under Load". Run the unit at least 30 minutes with loads applied.
6. Turn off all electrical loads by setting the generator main circuit breaker to "OFF" or "OPEN."
7. Let the unit run at no-load for a few minutes to stabilize internal engine-generator temperatures. Then, shut down the engine.

IMPORTANT: THE GENERATOR SET WAS THOROUGHLY TESTED AND ADJUSTED AT THE FACTORY BEFORE SHIPPING. NO ADDITIONAL ADJUSTMENT SHOULD BE NECESSARY. ONLY QUALIFIED SERVICE TECHNICIANS WHO HAVE BEEN TRAINED SHOULD PERFORM ADJUSTMENTS OUTLINED IN THIS MANUAL.

TESTING UNDER LOAD

Apply electrical loads equal to about 75-100% of the unit's rated wattage/ampere capacity.

Let the unit run at least 30 minutes with load applied. During this part of the test, check that the unit is not running excessively hot and that adequate cooling air flow is available. You must not allow the unit to overheat during prolonged operation.

NOTE: The generator engine is equipped with a high temperature switch. The switch has normally-open (N.O.) contacts. When the temperature is too high, switch contacts close, and engine shuts down automatically.

IMPORTANT: GENERAC RECOMMENDS THAT YOU TEST THE GENERATOR FOR ADEQUATE COOLING.

INSTALLATION CHECK LIST

LOCATION AND SUPPORT

- 1. The generator is properly located.
- 2. The generator is properly supported.
- 3. The generator is properly restrained.

COMPARTMENT

- 1. Compartment construction is proper.
- 2. Holes/openings are vapor-sealed.
- 3. Compartment size is correct.
- 4. Compartment is vapor-sealed.
- 5. Sound insulation is O.K.
- 6. Floor cutouts properly completed.

COOLING and VENTILATING AIR

- 1. Air flow is adequate.
- 2. Air inlet opening is correct.
- 3. Compensate for restrictions
- 4. Installation has been tested

GASOLINE FUEL SYSTEM

- 1. Fuel tank complies with code.
- 2. Fuel system properly installed.

EXHAUST SYSTEM

- 1. Complies with code requirements.
- 2. Properly and safely installed.

ELECTRICAL CONNECTIONS

- 1. Comply with code requirements.
- 2. Junction box properly installed.
- 3. Wiring meets all standards.
- 4. All connections are correct.
- 5. Conduit properly installed and sealed.
- 6. Generator properly bonded to vehicle.

BATTERY INSTALLATION

- 1. Recommended battery is installed.
- 2. Recommended cables are installed.
- 3. Cables are clean and tight.
- 4. Cables are properly connected.
- 5. Proper ventilation is provided.

POST INSTALLATION TESTS

- 1. All tests properly completed.

OPTIONS AND ACCESSORIES

Check that remote start/stop panels (if used) are properly installed.

If an hourmeter kit is installed, check that job was done properly.

If any other options and accessories are installed, check that they were installed properly.

DATE OF INSTALLATION

NAME OF INSTALLER

SIGNATURE OF INSTALLER

TROUBLESHOOTING

PROBLEM	POSSIBLE CAUSES	REMEDY
Engine won't crank.	<ol style="list-style-type: none"> 1. 15 amp fuse is blown 2. Loose corroded or defective battery cables. 3. Defective engine Start/Stop switch. 4. Defective starter contactor. 5. Defective starter motor. 6. Low or defective Battery 	<ol style="list-style-type: none"> 1. Replace 15 amp fuse 2. Tighten, clean or replace as necessary. 3. Replace Start/Stop switch. 4. Replace contactor. 5. Replace starter motor. 6. Charge or replace battery.
Engine cranks but won't start.	<ol style="list-style-type: none"> 1. Out of fuel. 2. Fuel pump is defective. 3. Open Wire #14 from Eng. Control Bd. 4. Engine is flooded. 5. Spark plug defective. 	<ol style="list-style-type: none"> 1. Replenish fuel. 2. Replace fuel pump. 3. Reconnect wire. 4. Wait 5-10 min. before trying. 5. Clean, regap or replace plug.
Engine starts hard, runs rough, low full load power.	<ol style="list-style-type: none"> 1. Air cleaner plugged or damaged 2. Defective spark plug. 3. Loose spark plug boot. 	<ol style="list-style-type: none"> 1. Clean or replace as needed. 2. Clean, regap or replace plug. 3. Press boot on securely.
Engine starts, shuts down when Start/Stop switch is released.	<ol style="list-style-type: none"> 1. Engine oil is low. 2. Engine is overheated. 3. Defective Low Oil Pressure System 4. Defective Engine Control Board 5. Defective Computer Control Board 	<ol style="list-style-type: none"> 1. Check oil; add as needed. 2. Check adequate ventilation. 3. Have serviced/replaced. 4. Have board serviced/replaced. 5. Have board serviced/replaced.
Start/Stop switch at Stop, engine continues to run.	<ol style="list-style-type: none"> 1. Defective Start/Stop switch 2. Open/disconnected wire #18 between Start/Stop switch and Engine Control 3. Open/disconnected wire #0 between Start/Stop switch & Engine Control Bd. 4. Defective Engine Control Board 	<ol style="list-style-type: none"> 1. Replace switch. 2. Reconnect or close wire. 3. Reconnect or close wire. 4. Replace board.
No AC output from generator.	<ol style="list-style-type: none"> 1. Check circuit breaker. 2. Check vehicle circuit breaker & fuses. 3. Transfer sw. set to NORMAL position. 4. Generator internal failure 	<ol style="list-style-type: none"> 1. Reset to ON or CLOSED. 2. Reset and replace if necessary. 3. Set to GENERATOR position. 4. Take generator to an Authorized Generac facility.

MAJOR FEATURES AND DIMENSIONS

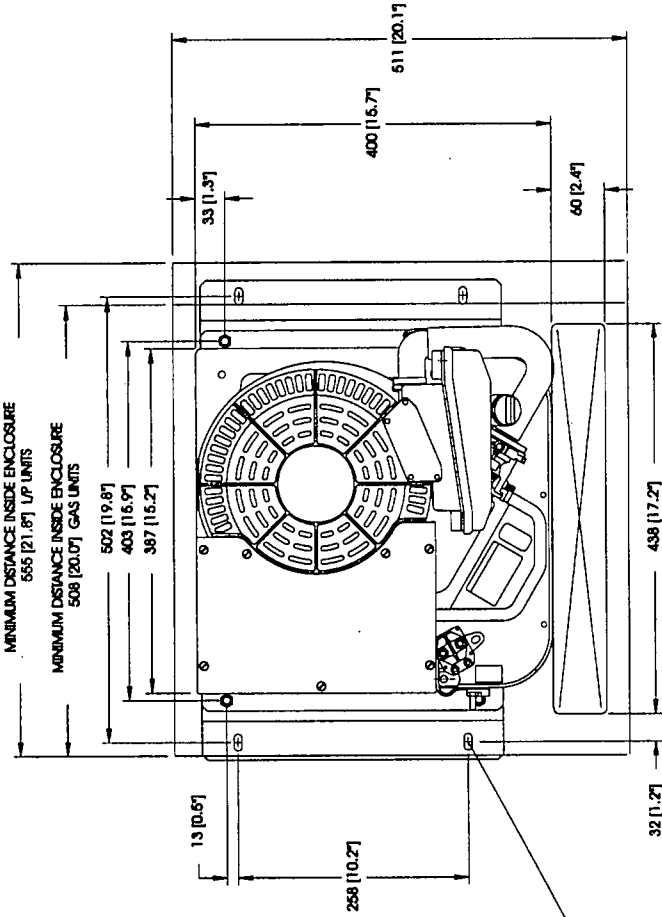

#1/8 MOUNTING FASTENERS
(4 TOTAL REQUIRED)

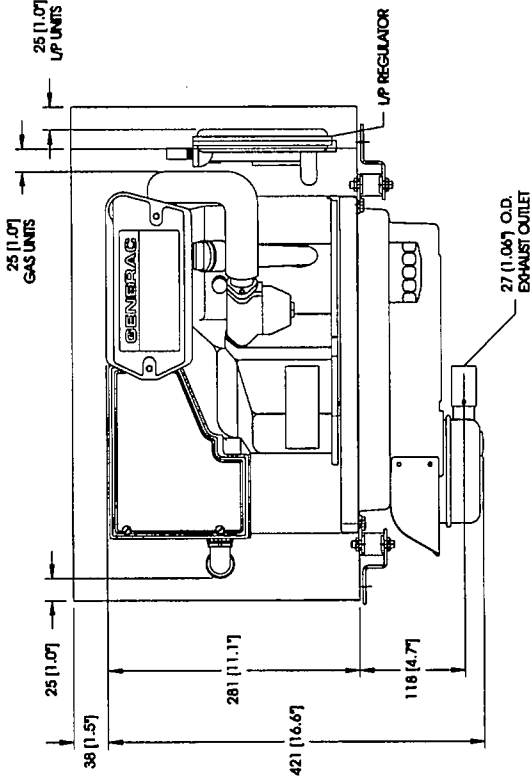
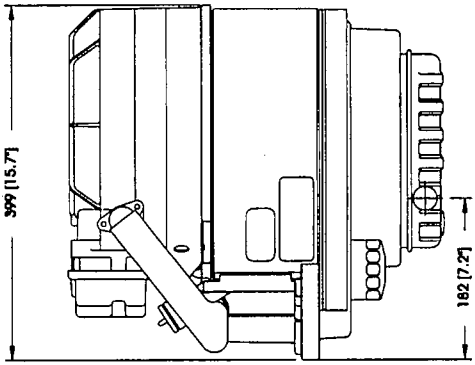

ELECTRICAL DATA

Drawing No. A2420 Rev. A

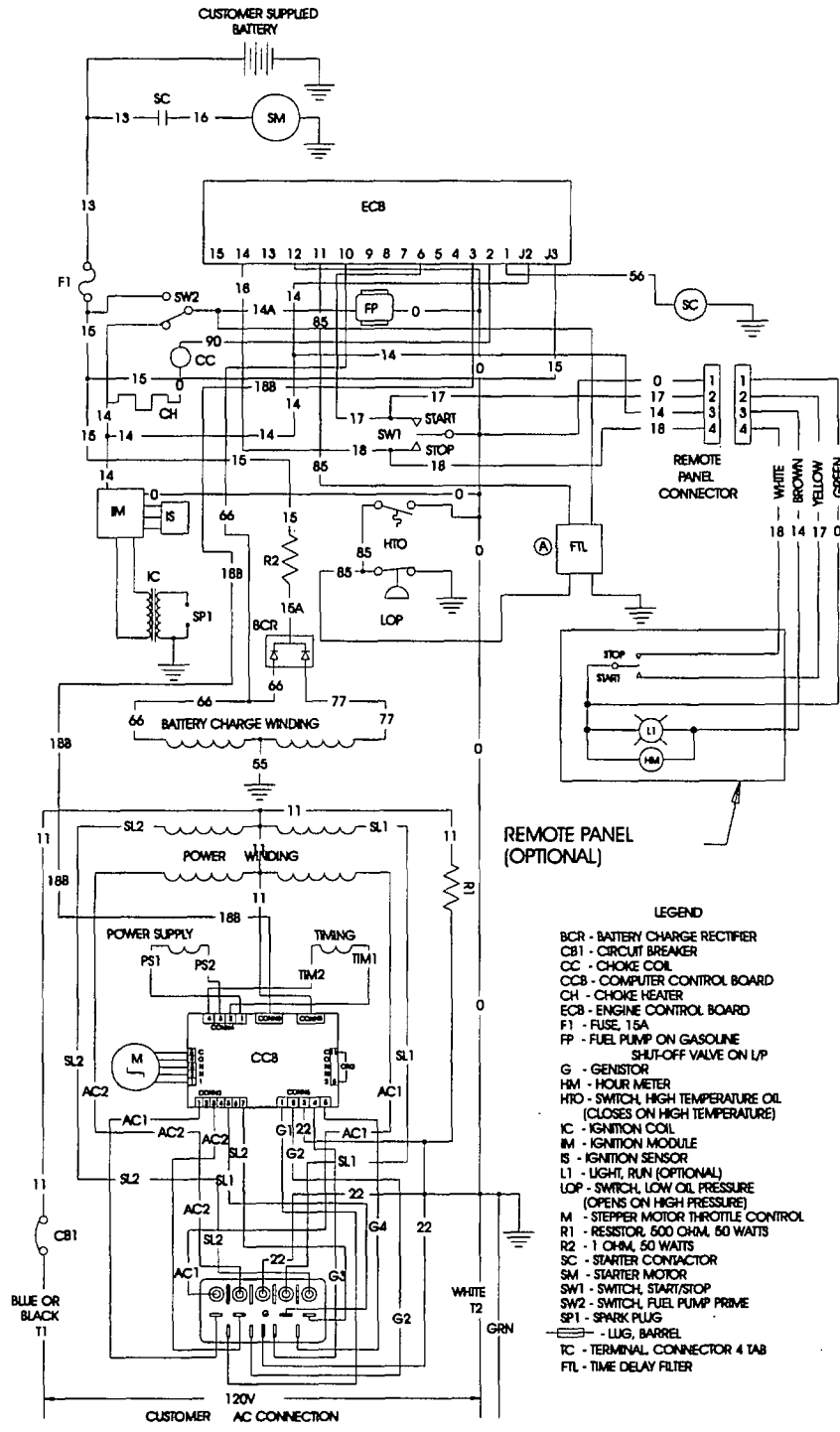

- LEGEND**
- BCR - BATTERY CHARGE RECTIFIER
 - CB1 - CIRCUIT BREAKER
 - CC - CHOKE COIL
 - CCB - COMPUTER CONTROL BOARD
 - CH - CHOKE HEATER
 - ECB - ENGINE CONTROL BOARD
 - F1 - FUSE, 15A
 - FP - FUEL PUMP ON GASOLINE SHUT-OFF VALVE ON L/P
 - G - GENISTOR
 - HM - HOUR METER
 - HTO - SWITCH, HIGH TEMPERATURE OIL (CLOSES ON HIGH TEMPERATURE)
 - IC - IGNITION COIL
 - IM - IGNITION MODULE
 - IS - IGNITION SENSOR
 - L1 - LIGHT, RUN (OPTIONAL)
 - LOP - SWITCH, LOW OIL PRESSURE (OPENS ON HIGH PRESSURE)
 - M - STEPPER MOTOR THROTTLE CONTROL
 - R1 - RESISTOR, 500 OHM, 50 WATTS
 - R2 - 1 OHM, 50 WATTS
 - SC - STARTER CONDUCTOR
 - SM - STARTER MOTOR
 - SW1 - SWITCH, START/STOP
 - SW2 - SWITCH, FUEL PUMP PRIME
 - SP1 - SPARK PLUG
 - TC - LUG, BARREL
 - FIL - TIME DELAY FILTER

ELECTRICAL DATA

Drawing No. A2420 Rev. A

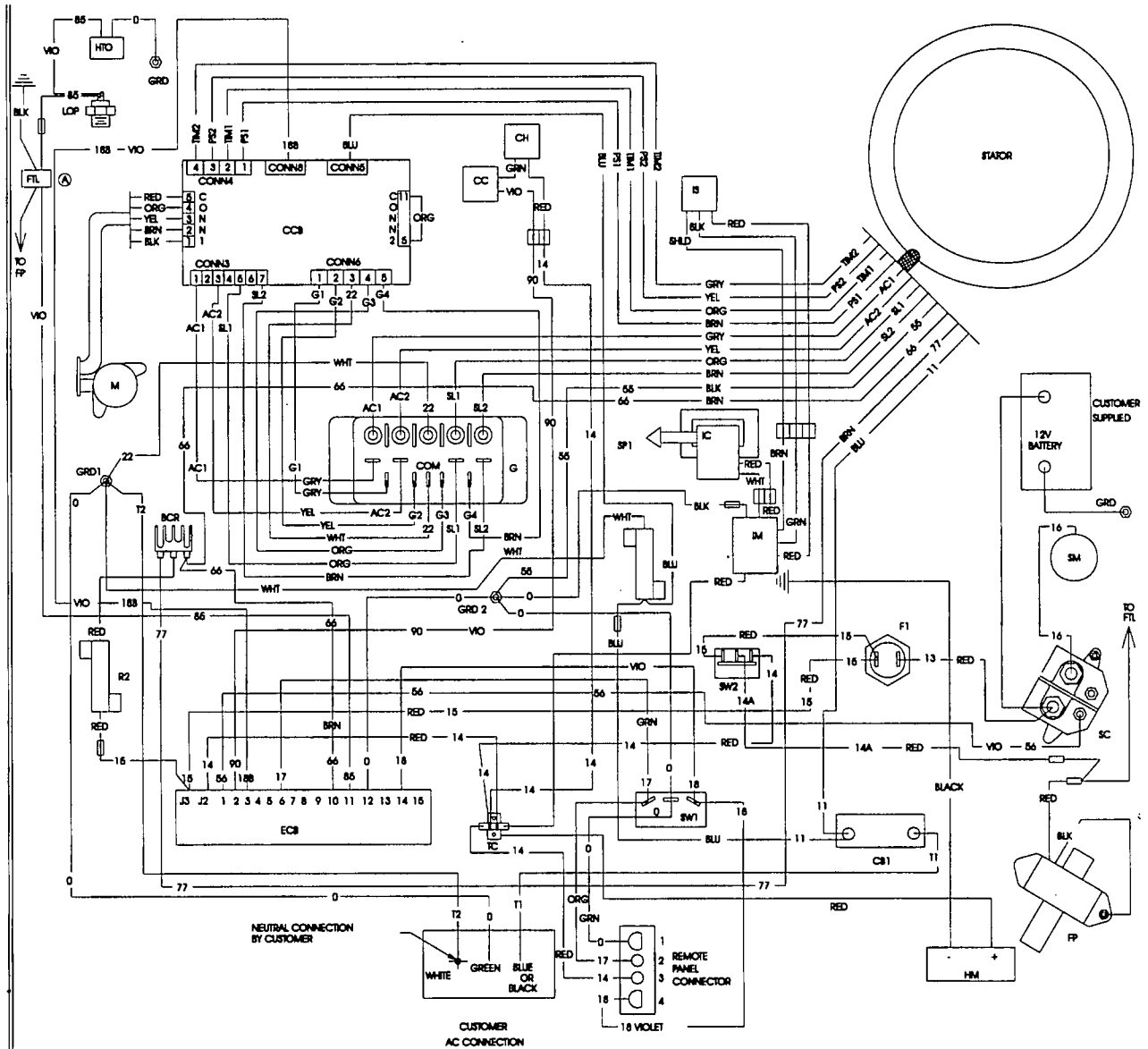

EXPLODED VIEW — GENERATOR

Drawing No. A5969 Rev A

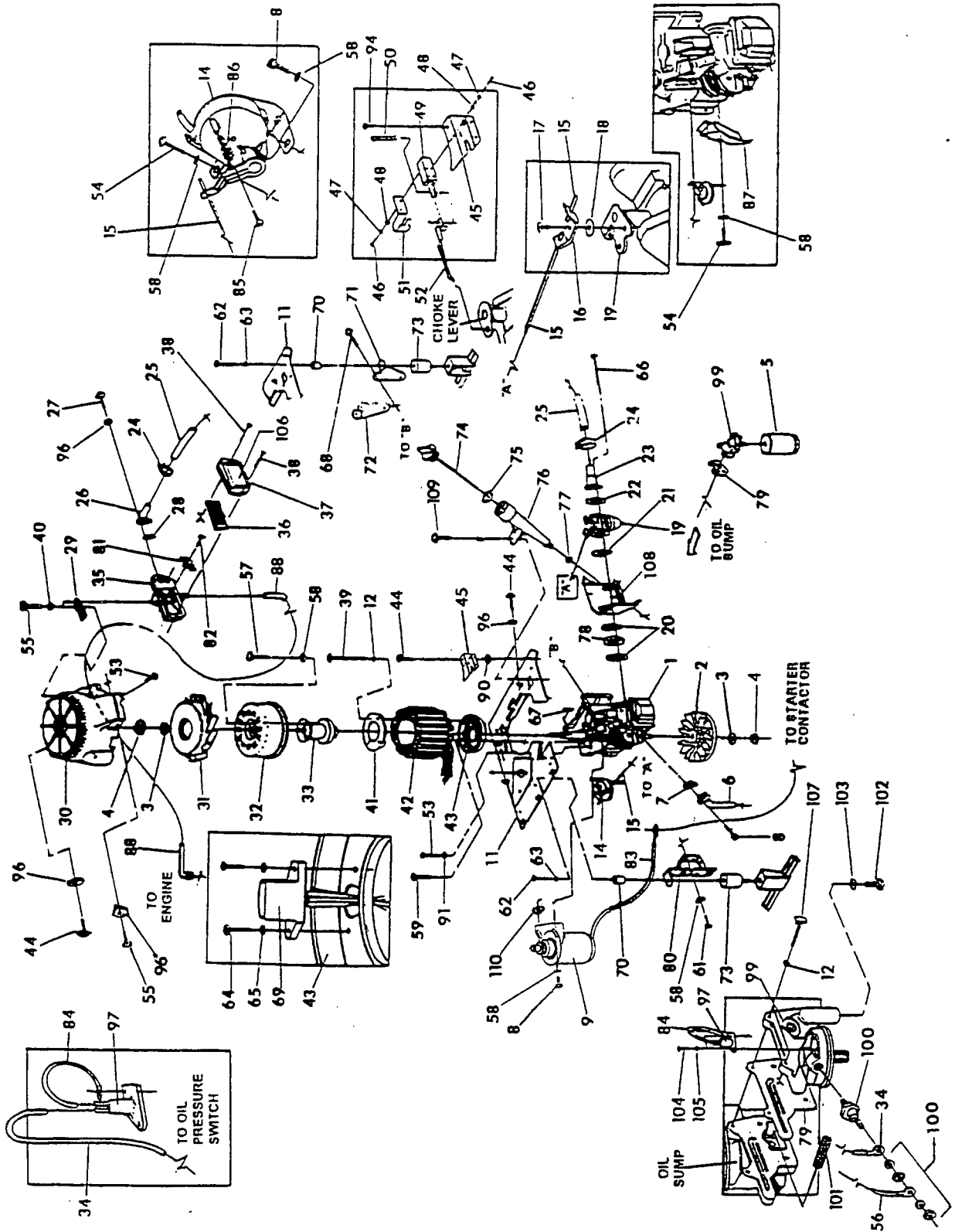

REPAIR PARTS — GENERATOR

Drawing No. A5969 Rev. A

ITEM	PART NO.	QTY.	DESCRIPTION	ITEM	PART NO.	QTY.	DESCRIPTION
1	A2467	1	ENGINE, LONG BLOCK	55	52618	5	M5-0.8 X 12MM CPSCR.
2	94583	1	FLYWHEEL, FAN	56	005-91297	1	OIL PRESS. SWITCH WIRE
3	83312	2	WASHER, CONICAL	57	42907	3	HEX HD. CAPSCREW, M8-1.25 X 16MM
4	81810	2	HEX NUT, M16-1.5				
5	70185	1	FILTER, OIL	58	22129	10	LOCKWASHER - M8
6	86730	1	TUBE, EXHAUST OUTLET	59	74906	4	M6-1 X 20MM TAPTITE
7	89476	1	GASKET, EXHAUST	61	39253	3	HEX HD. CAPSCREW, M8-1.25 X 20MM
8	40976	4	SOCKET HD. CAPSCR., M8-1.25 X 20MM	62	22511	3	HEX HD. CAPSCREW, 3/8"-16 X 1.25"
9	99948	1	STARTER, EATON/GENERAC				
11	86705	1	PLATE, DIVIDER	63	22237	3	LOCKWASHER - 3/8"
12	22097	8	LOCKWASHER, 1/4"-M6	64	55822	2	PHMS, M4-.7 X 8MM
14	92059	1	STEPPER MOTOR SPEED CONTROL	65	22264	2	LOCKWASHER - M4
				66	89050	2	PPHMS - M6-1 X 90MM
15	86706	1	ROD, THROTTLE CONTROL	67	82774	1	WOODRUFF KEY- 4MM X 19MM
16	89477	1	CLIP, ADJUSTMENT				
17	89478	1	SNAP, RETAINING	68	59637	4	TAPTITE 3/8"-16 X .75"
18	90192	1	WASHER, CARBURETOR	69	86697	1	ASSY. IGNITION SENSOR
19	90881A	1	ASSEMBLY., CARBURETOR	70	86704	3	SPACER, ENGINE MOUNT
20	90051	2	GASKET, CARB./SPACER/HEAD	71	86701	1	BRCKT., ENG. MNT. FRONT
				72	86702	1	BRCKT., ENG. MNT. REAR
21	78631	1	GASKET, CARB./SKIRT	73	38353	3	RUBBER MOUNTS
22	96459	1	GASKET, CARB./INLET ADAPTOR	74	89263	1	ASSY., OIL FILL CAP
				75	90071	1	O-RING, 1.062" I.D.
23	86709	1	ADAPTOR, CARB. INLET	76	94637	1	OIL FILL TUBE
24	35586	2	HOSE CLAMP-BAND 1.50"	77	90072	1	O-RING .562" I.D.
25	86710	1	HOSE, CARB. INLET	78	86708	1	CARBURETOR SPACER
26	87993	1	ELBOW, AIR CLNR. OUTLET	79	87478	1	GASKET, OIL FILTER ADAPTOR
27	49815	2	HEX HD. CAPSCREW, M5-.8 X 16MM	80	96627	1	BRACKET, STARTER SIDE ENGINE MOUNT
28	90536	1	GASKET, AIR CLEANER OUTLET	81	90613	1	COVER, BREATHER CANAL
29	90021	1	BRACKET., AIR CLEANER SUPPORT	82	59635	1	#8 X 3/8" PLASTITE SCREW
				83	002-91297	1	STARTER WIRE
30	94665	1	HOUSING, FAN-UPPER	84	004-91297	1	TEMP. SWTCH GRND WIRE
31	93859	1	FAN, GENERATOR	85	59636	1	PLASTITE SCREW, #4 X .37"
32	A5892	1	ASSY., MAGNET HOUSING	86	88905	1	EXTENSION SPRING
33	91437	1	HUB, MAGNET HOUS. ASSY.	87	92800	1	WRAPPER, ENGINE TOP
34	003-91297	1	TEMP. SWITCH WIRE	88	89062	1	HOSE, BREATHER
35	86673	1	BASE, AIR BOX	90	23762	2	WASHER, EXTERNAL SHAKEPROOF - #10
36	78601	1	ELEMENT, AIR FILTER\				
37	86674	1	COVER, AIR BOX	91	22447	3	WASHER, INTERNAL SHAKEPROOF - .25"
38	78609	2	BOLT, AIR CLNR. COVER				
39	66449C	4	HEX HD. CAPSCREW, M6-1 X 80MM	94	23484P	1	SNAP BUSHING
				96	23897	6	#10-M5 FLAT WASHER
40	49226	4	LOCKWASHER, M5	97	94090	1	SWITCH-THERM., OIL TEMP.
41	80934	1	RETAINING RING, STATOR	99	86675A	1	ADAPTOR, OIL FILTER
42	A5898	1	ASSEMBLY STATOR	100	77667	1	SWITCH, OIL PRESSURE
43	86692	1	ADAPTOR, STATOR	101	86714	1	SCREEN, OIL PICK-UP
44	74908	3	TAPTITE, M5-0.8 X 10MM	102	52617	1	DRAIN PLUG, M12-1.75 X 20MM
45	86735	1	COVER, CHOKE MOUNT				
46	47488	4	SCREW, 4-40 X .188"	103	94643	1	GASKET, OIL DRAIN PLUG
47	22159	4	LOCKWASHER - #4	104	70728	2	SCREW, M3-0.5 X 5MM
48	31879	4	FLATWASHER - #4	105	43182	2	LOCKWASHER, M3
49	91306	1	SOLENOID, CHOKE	106	A1627	1	AIR CLEANER DECAL
50	36544	1	PIN, COTTER 3/32" X 1/2"	107	A8617	4	HEX HD. TAPTITE M6-1X25MM
51	89473	1	ASSY., BI-METAL & HEATER	108	86726	1	SKIRT, BAFFLE
52	86736	1	LINKAGE, CHOKE CONT.	109	56893	1	CRIMPTITE, 10-24 X 1/2"
53	45756	3	M6-1 X 10MM TAPTITE	110	A9257	1	SHIM, STARTER
54	83512	1	TAPTITE M8-1.25 X 15MM				

EXPLODED VIEW — ENGINE LONG BLOCK

Drawing No. A6202 Rev. B

DATE: AUG. 10, 1998

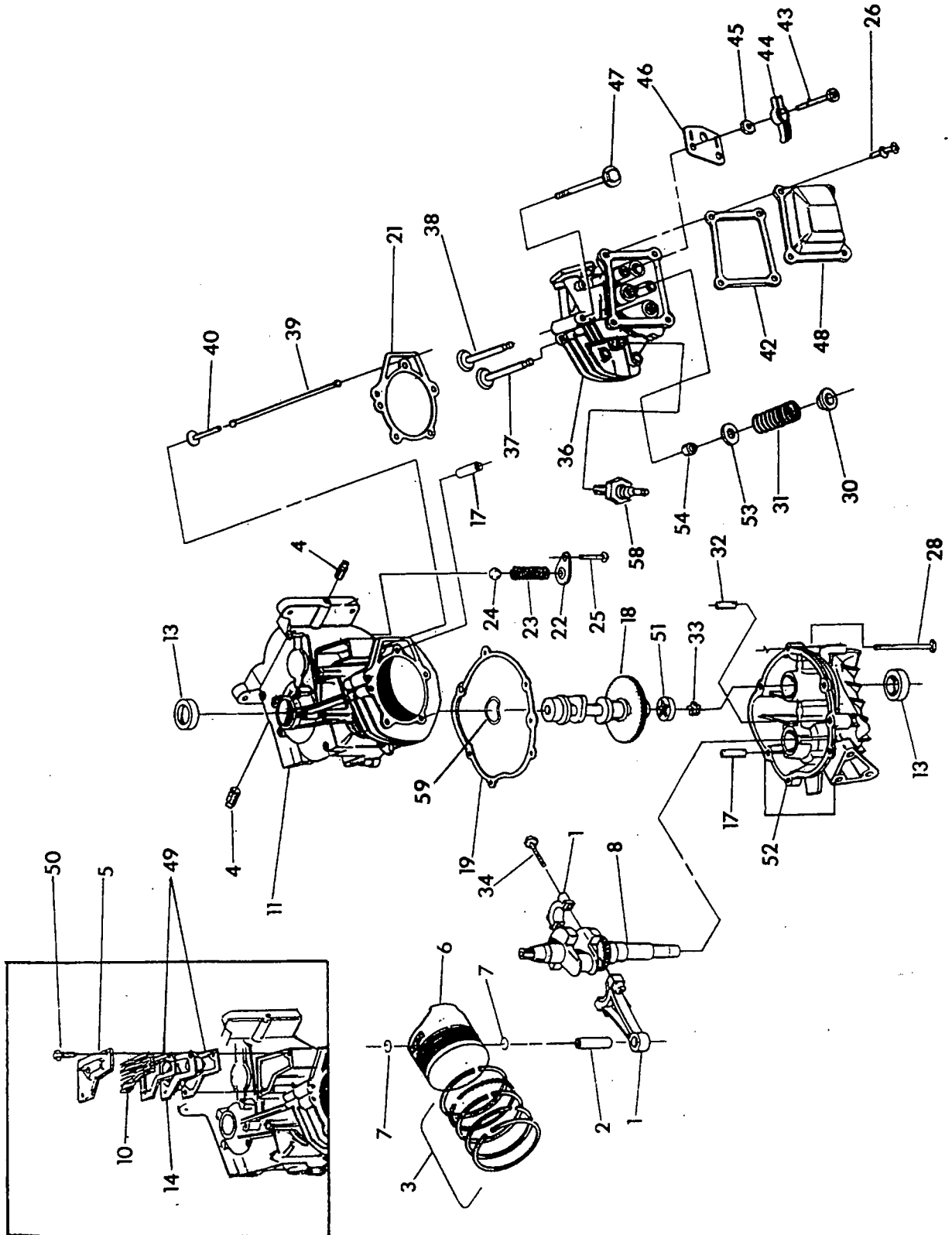

REPAIR PARTS — ENGINE LONG BLOCK

Drawing No. A6202 Rev. B

DATE: AUG. 10, 1998

ITEM	PART NO.	QTY.	DESCRIPTION
1	76380	1	ASSEMBLY, CONNECTING ROD & CAP
2	76389	1	PISTON PIN
3	88411	1	SET, PISTON RING (STD. SIZE)
4	72657	2	PIPE PLUG-1/4 NPT
5	77176	1	COVER, BREATHER
6	88057	1	PISTON, 75 DIA.
7	76390	2	RETAINER, PISTON PIN
8	21860	1	ASSEMBLY, CRANKSHAFT AND GEAR
10	89923	1	SEPARATOR, OIL BREATHER
11	89213L	1	ASSEMBLY, CRANKCASE
13	81695	2	SEAL, OIL-CRANKSHAFT
14	90604	1	CUP, BREATHER BAFFLE
17	78699B	3	SLEEVE, DOWEL Ø 12
18	A2477	1	ASSEMBLY, CAMSHAFT
19	89096	1	GASKET, CRANK CASE FLANGE
21	A8822	1	GASKET, CYLINDER HEAD
22	78691	1	RETAINER, OIL PRESSURE SPRING
23	A5772	1	SPRING, OIL PRESSURE
24	A5776	1	BALL, OIL PRESSURE
25	74908	1	TAPTITE, M5-0.8 x 10
26	78606	4	SCREW & LOCK WASHER, M6-1 x 12 LONG
28	89230	6	HHFC, M8-1.25 x 35 LONG
30	A1720	2	RETAINER, VALVE SPRING
31	88401	2	SPRING, VALVE
32	88590	1	DOWEL PIN, DIA. 12 x 18 LONG
33	83152	1	GEROTOR, INNER
34	76381	2	BOLT, CONNECTING ROD
36	21705B	1	ASSEMBLY, CYLINDER HEAD W/GUIDES & SEATS
37	90082	1	VALVE, EXHAUST
38	90081	1	VALVE, INTAKE
39	88396A	2	PUSH ROD
40	83235	2	TAPPET
42	96362	1	GASKET, ROCKER COVER
43	77161	2	STUD, BALL PIVOT
44	77160	2	ROCKER ARM
45	76307	2	NUT, ROCKER ARM
46	88403	1	PLATE, PUSH ROD GUIDE
47	77168	5	HEADBOLT, M8 x 52MM
48	88413B	1	COVER, ROCKER
49	78629	2	GASKET, BREATHER
50	90388	2	BOLT, TAPTITE-M6 x 12 LONG
51	83153	1	GEROTOR, OUTER
52	92977	1	ASSEMBLY-SUMP, OIL
53	84186	2	WASHER, WEAR-VALVE SPRING
54	88156	1	SEAL VALVE-INTAKE
58	72347	1	SPARK PLUG, CHAMPION RC12YC
59	99922	1	WASHER, SPRING

REPAIR PARTS — CONTROL PANEL

Drawing No. A9404 Rev. *

ITEM	PART NO.	QTY.	DESCRIPTION	ITEM	PART NO.	QTY.	DESCRIPTION
1	91526	8	M50.8 x 12MM PHILLIPS PAN HD. MACH. SCR.	34	43182	4	LOCK WASHERM3
2	20093	1	BOX, CONTROL TOP	35	89744	1	RESISTOR, POWER 1 OHM
3	20092	1	BOX, CONTROL PANEL	36	83491	1	RESISTOR, POWER 500 OHM
4	36937	2	#10-32 x 1" PHILLIPS PAN HD. MACH. SCR.	37	45756	4	TAPTITE M61 x 10 LONG
5	75476	5	PHILLIPS PAN HD. MACH. SCR., M4 x 16	38	86722	1	BRACKET, HEAT SINKPCB
6	74908	8	TAPTITE M5.8 x 10 LONG	41	75210A	1	TERMINAL BLOCK
7	23484M	1	SNAP BUSHING	42	91281	1	12 PIN CONNECTOR ASSY.
8	20107	1	90 DEG. CONNECTOR	43	86738A	1	TRIAC MODULE HARNESS
9	92234	1	RV CONTROL BOARD	44	00191297	1	GROUND WIRE
10	90145	1	CIRCUIT BREAKER30A.	45	91282	1	CUSTOMER WIRE HARNESS
13	49226	10	LOCK WASHER M5	46	91269A	1	REMOTE PANEL HARNESS
14	51715	2	HEX NUT M4	47	23484D	1	SNAP BUSHING
18	22985	4	M4 FLAT WASHER	48	82121A	2	CLAMP, CONTROL PANEL HARNESS
19	23897	8	M5 FLAT WASHER	49	20106	1	HARNESS, CONT. PANEL (NOT SHOWN FOR CLARITY)
20	20091	1	CONTROL PANEL, FRONT	50	25105	2	#632 x 1/4" PHILLIPS RND. HD. MACH. SCREW
21	30809	1	RUBBER GROMMET	51	84867	4	RUBBER UCHANNEL
22	87798	1	SWITCH, SPDT ROCKER	52	51718	4	M40.7 x 10MM HEX HEAD CAPSCREW
23	92113	1	SWITCH, SPSTMOM ROCKER	53	77604	1	HOUR METER
24	A9611	1	FUSE, 7.5A. AGC	54	34028	2	#440 x 3/8" LG. ROUND HD.
25	32300	1	FUSE HOLDER	55	22159	2	#4 LOCKWASHER
26	80939	1	EXTRUSION, CONTROLLER	56	27771	2	#440 HEX NUT
27	65795	1	RECTIFIER, BATT CHARGE	57	36933	2	PPHMS 10-32 x 3/8" LONG
28	22264	16	LOCK WASHER M4	58	23762	1	SHAKEPROOF LOCK WASHER, EXTERNAL TOOTH #10
29	22158	2	#1032 HEX NUT	59	29333A	2	BLACK TIE WRAP, 7" LONG
30	20105B	1	PANEL DECAL	60	23762	2	SHAKEPROOF EXT. #10
31	86275	1	GENISTOR, TRIAC MODULE				
32	A3369	1	ASSEMBLY, PCB CCG				
33	43181	4	TAPTITE, M30.5 x 10MM PAN HD. MACH. SCR.				

EXPLODED VIEW — ENGINE SHEET METAL

Drawing No. A9194 Rev A

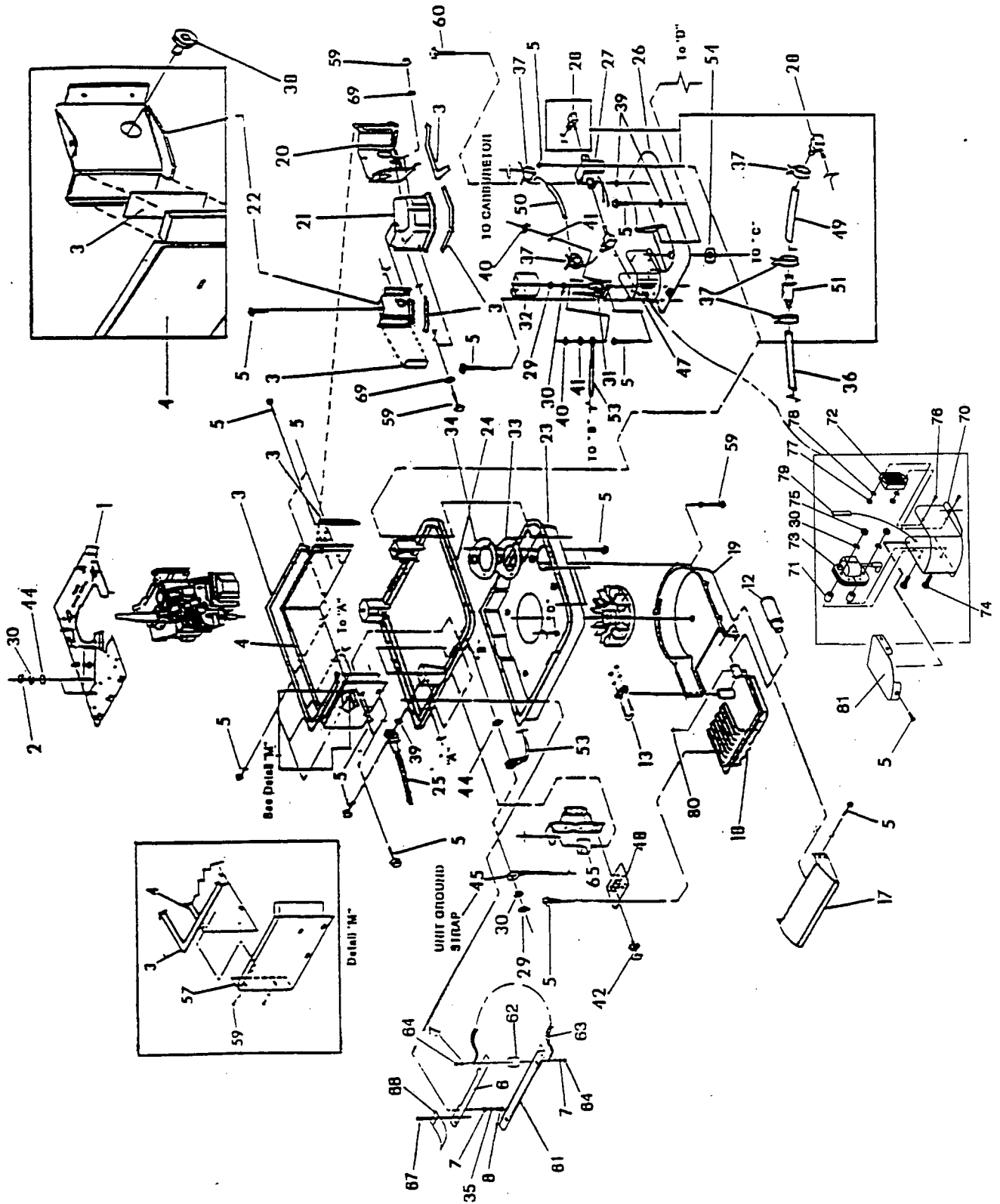

REPAIR PARTS — ENGINE SHEET METAL

Drawing No. A9194 Rev. A

ITEM	PART NO.	QTY.	DESCRIPTION	ITEM	PART NO.	QTY.	DESCRIPTION
1	86705	1	PLATE, DIVIDER	44	22447	3	WASHER, INT. SHAKEPROOF, 1/4"/M6
2	49813	2	M6-1.0 HEX NUT				
3	86718	3.5 FT.	SEAL RUBBER EXTRUSION	45	103-74260	1	GROUND STRAP, UNIT
4	A3666	1	WRAPPER, BOX	47	39450	1	1/8" X 3/16" NPT 90° BARBED FITTING
5	74908	33	TAPTITE, M5-.8 X 10MM LG.	48	92000	1	BRCKT., MUFFLER HANGER
6	A3667	2	MOUNTING BRACKET	49	30340	1	1/4" FUEL LINE (8" LONG)
7	22129	12	M8 LOCK WASHER	50	82580D	1	3/16" CARB. LINE (4" LONG)
8	39414	4	M8-1.25 X 35MM HEX HD. CAPSCREW	51	86311	1	FUEL FILTER
12	89680	1	SPARK ARRESTOR	53	007-91297	1	STARTER CONTACTOR GROUND WIRE
13	94670	1	CLAMP, EXHAUST				
17	89471	1	DEFLECTOR, AIR OUT	54	89045	1	SEAL, WASHER EXH. PIPE
18	86731A	1	ASSEMBLY, MUFFLER	57	A3638	1	PANEL, WRAPPER BOX
19	86715	1	HOUSING, LOWER FAN	59	56893	11	CRIMPTITE, #10-24 X 1/2"
20	86726	1	SKIRT, CARB. BAFFLE	60	A5767	1	HEX HD. CAPSCREW, M5-0.8 X 6MM
21	86671	1	COVER, ROCKER COVER	61	A3764	2	CUSTOMER MNTG. BRCKT.
22	86727	1	SKIRT, SPARK PLUG SIDE	62	66443B	4	VIBRATION MOUNT
23	86719	1	PAN, BELLY	63	20668	2	EARTHING STRAP
24	20519	1	FRAME	64	45771	8	HEX NUT - M8
25	90141A	1	GROUND STRAP	65	38353	3	VIBRATION MOUNT
26	86724	1	PLATE, BASE COVER	67	79119	2	TAPTITE 1/4"-20 X 1-1/4"
27	90475	1	PUMP, FUEL	68	A7213	2	TAG, REMOVE BOLT
28	28740	1	BARBED 90 1/8" X 1/4"	69	23897	4	FLAT WASHER #10/M5
29	22127	3	HEX NUT, 1/4"-20	70	A9172	1	BRACKET, IGNITION SYS.
30	22097	7	LOCK WASHER-1/4"/M6	71	89047	2	SPACER, IGNITION COIL
31	86729	1	CONTACTOR, STARTER	72	86711	1	MODULE, IGNITION
32	90518	1	BOOT, CONTACTOR	73	89049B	1	ASSY., IGNITION COIL
33	89048	1	SEAL, OIL FILTER HOLE	74	49721	2	M6-1.0X35MM H.H. CAPSCR.
34	90537	1	RETAINER, SEAL	75	49813	4	M6-1.0 HEX NUT
35	22145	4	M8 FLAT WASHER	76	91526	2	M5-0.8 X 12MM PPHMS
36	30340	1	1/4" FUEL LINE - 4" LONG	77	51716	2	M5-0.8 HEX NUT
37	48031C	5	1/4" HOSE CLAMP	78	49226	2	LOCK WASHER, M5
38	23484D	1	SNAP BUSHING	79	84867	.25 FT.	RUBBER "U" CHANNEL
39	23762	2	EXTERNAL SHAKEPROOF	80	56892	1	CRIMPTITE #10-24 X 3/8"
40	22471	2	#8 HEX NUT	81	A9196	1	COVER, IGNITION SYSTEM
41	22264	2	#8 LOCK WASHER				
42	79246	2	H.H.CPSCR., M6-1.0X16MM W/LOCKWASHER				

CALIFORNIA EMISSION CONTROL WARRANTY STATEMENT

YOUR WARRANTY RIGHTS AND OBLIGATIONS

The California Air Resources Board ("CARB") and Generac Power Systems Inc. are pleased to explain the Emission Control System Warranty on your new recreational vehicle equipment engine. In California, new utility and lawn and garden equipment engines must be designed, built and equipped to meet the State's stringent anti-smog standards. Generac Power Systems Inc. will warrant the emission control system on your recreational vehicle equipment for the periods of time listed below provided there has been no abuse, neglect, unapproved modification, or improper maintenance of your recreational vehicle equipment engine.

Your emission control system may include parts such as the carburetor, ignition system and exhaust system. Also included may be the compression release system and other emission-related assemblies.

Where a warrantable condition exists, Generac Power Systems Inc. will repair your recreational vehicle equipment engine at no cost to you for diagnosis, parts and labor.

MANUFACTURER'S EMISSION CONTROL SYSTEM WARRANTY COVERAGE:

Emissions control systems on 1995 and later model year utility and lawn and garden equipment engines are warranted for two years as hereinafter noted. If, during such warranty period, any emission-related part on your engine is defective in materials or workmanship, the part will be repaired or replaced by Generac Power Systems Inc..

OWNER'S WARRANTY RESPONSIBILITIES:

As the recreational vehicle equipment engine owner, you are responsible for the performance of the required maintenance listed in your owners manual. Generac Power Systems Inc. recommends that you retain all receipts covering maintenance on your recreational vehicle equipment engine, but Generac Power Systems Inc. will not deny warranty solely due to the lack of receipts or for your failure to provide written evidence of the performance of all scheduled maintenance.

As the recreational vehicle equipment engine owner, you should, however, be aware that Generac Power Systems Inc. may deny you warranty coverage if your recreational vehicle equipment engine or a part thereof has failed due to abuse, neglect, improper maintenance or unapproved modifications.

You are responsible for presenting your recreational vehicle equipment engine to a Generac Power Systems Inc. Authorized Service Outlet as soon as a problem exists. The warranty repairs should be completed in a reasonable amount of time, not to exceed 30 days.

Warranty service can be arranged by contacting either a Generac Power Systems Inc. Authorized Service Outlet or by contacting Generac Power Systems Inc. at:

GENERAC POWER SYSTEMS INC. PH: (414) 473-5514
P.O. BOX 8 FX: (414) 472-6505
WAUKESHA, WI 53187

IMPORTANT NOTE: This warranty statement explains your rights and obligations under the Emission Control System Warranty ("ECS Warranty") which is provided to you by Generac Power Systems Inc. pursuant to California law. See also the Generac Power Systems Inc. Limited Warranties for Generac Power Systems Inc. which is enclosed herewith on a separate sheet and also is provided to you by Generac Power Systems Inc.. The ECS Warranty applies only to the emission control system of your new engine. To the extent that there is any conflict in terms between the ECS Warranty and the Generac Power Systems Inc. Warranty, the ECS Warranty shall apply except in any circumstances in which the Generac Power Systems Inc. Warranty may provide a longer warranty period. Both the ECS Warranty and the Generac Power Systems Inc. Warranty describe important rights and obligations with respect to your new engine.

Warranty service can only be performed by a Generac Power Systems Inc. Authorized Service Outlet. At the time of requesting warranty service, evidence must be presented of the date of the sale to the original purchaser. The purchaser shall pay any charges for making service calls and/or for transporting the products to and from the place where the inspection and/or warranty work is performed. The purchaser shall be responsible for any damage or loss incurred in connection with the transportation of any engine or any part(s) thereof submitted for inspection and/or warranty work.

EMISSION CONTROL SYSTEM WARRANTY

Emission Control System Warranty ("ECS Warranty") for 1995 and Later Model Year Utility and Lawn and Garden Equipment Engines:

A. **Applicability:** This warranty shall apply to 1995 and later model year utility and lawn and garden equipment engines. The ECS Warranty Period ("ECS Warranty Period") shall begin on the date the new engine or equipment is delivered to its original, end-use purchaser and shall continue for 24 consecutive months thereafter.

B. **General Emissions Warranty Coverage:** Generac Power Systems Inc. warrants to the original, end-use purchaser of the new engine or equipment and to each subsequent purchaser that each of its utility and lawn and garden equipment engines is:

1. Designed, built and equipped so as to conform with all applicable regulations adopted by the Air Resources Board pursuant to its authority, and
2. Free from defects in materials and workmanship which, at any time during the ECS Warranty Period, will cause a warranted emissions - related part to fail to be identical in all material respects to the part as described in the engine manufacturer's application for certification.

C. The ECS Warranty only pertains to emissions-related parts on your engine, as follows:

1. Any warranted, emissions-related parts which are not scheduled for replacement as required maintenance in the Owner's Manual shall be warranted for the ECS Warranty Period. If any such part fails during the ECS Warranty Period, it shall be repaired or replaced by Generac Power Systems Inc. according to Subsection (4) below. Any such part repaired or replaced under the ECS Warranty shall be warranted for any remainder of the ECS Warranty Period.
2. Any warranted, emissions-related part which is scheduled only for regular inspection as specified in the Owner's Manual shall be warranted for the ECS Warranty Period. A statement in such written instructions to the effect of "repair or replace as necessary" shall not reduce the ECS Warranty Period. Any such part repaired or replaced under the ECS Warranty shall be warranted for any remainder of the ECS Warranty Period.
3. Any warranted, emissions-related part which is scheduled for replacement as required maintenance in the Owner's Manual shall be warranted for the period of time prior to first scheduled replacement point for that part. If the part fails prior to the first scheduled replacement, the part shall be repaired or replaced by Generac Power Systems Inc. according to Subsection (4) below. Any such emissions-related part repaired or replaced under the ECS Warranty shall be warranted for the remainder of the ECS Warranty Period prior to the first scheduled replacement point for such emissions-related part.
4. Repair or Replacement of any warranted, emissions-related part under this ECS Warranty shall be performed at no charge to the owner at a Generac Power Systems Inc. Authorized Service Outlet.
5. The owner shall not be charged for diagnostic labor which leads to the determination that a part covered by the ECS Warranty is in fact defective, provided that such diagnostic work is performed at a Generac Power Systems Inc. Authorized Service Outlet.
6. Generac Power Systems Inc. shall be liable for damages to other original engine components or approved modifications proximately caused by a failure under warranty of any emission-related part covered by the ECS Warranty.
7. Throughout the ECS Warranty Period, Generac shall maintain a supply of warranted emission-related parts sufficient to meet the expected demand for such emission-related parts.
8. Any Generac Power Systems Inc. authorized and approved emission-related replacement part may be used in the performance of any ECS warranty maintenance or repairs and will be provided without charge to the owner. Such use shall not reduce Generac Power Systems Inc. ECS warranty obligations.
9. Unapproved add-on modified parts may not be used to modify or repair a Generac Power Systems Inc. engine. Such use voids this ECS Warranty and shall be sufficient grounds for disallowing an ECS Warranty claim. Generac Power Systems Inc. shall not be liable hereunder for failures of any warranted parts of a Generac Power Systems Inc. engine caused by the use of such an unapproved add-on or modified part.

EMISSION RELATED PARTS INCLUDE THE FOLLOWING:

1. Carburetor assembly and its internal components.
 - a. Fuel filter
 - b. Carburetor gaskets
 - c. Fuel pump (if so equipped)
2. Air cleaner assembly
 - a. Air filter element
 - b. Intake pipe/manifold
3. Ignition system including:
 - a. Spark plug
 - b. Ignition module
4. Catalytic muffler (if so equipped)
 - a. Muffler gasket (if so equipped)
 - b. Exhaust manifold (if so equipped)
5. Crankcase breather assembly and its components.
 - a. Breather connection tube

Generac's Three-Year Limited Warranty For Recreational Vehicle Generators

Generac warrants to the original owner and subsequent purchasers from the date of purchase by the original owner, that its generators will be free from defects in materials or workmanship for the period as set forth below. During said warranty period, Generac will, at its option, repair or replace any part which, upon examination by Generac or a Generac Authorized Distributor and/or Dealer thereof, is found to be defective from normal use and service.

This warranty is only effective, upon Generac's receipt from the original owner, a completed Warranty Registration Card, prior to the expiration of the warranty period. This card is the only valid registration identification and must be presented at time of requesting Warranty service. Claims will not be accepted without presentation of this Registration Card.

THREE YEAR WARRANTY SCHEDULE

1. All generators used in a recreational vehicles shall be warranted for a period of three (3) years or 2,000 hours of operation, whichever occurs first. All parts, labor, removal and reinstallation shall be covered for the first two years. Parts and labor on selected generator and engine parts shall be covered during the third year or 2,000 hours, whichever occurs first. These selected parts are limited to: the main Rotor and Stator, Computer Control board (if applicable) with regard to the generator; the Cylinder Block, Cylinder Head, Crankshaft, Piston, Valve, Valve Lifter, and Manifolds with regard to the engine.
2. The drive belt and pulleys (if so equipped) on air-cooled generator used in recreational vehicles shall be warranted against failure due to defective materials or normal usage for the life of the generator. For the original owner, this drive belt and pulley warranty shall include parts and labor plus \$50.00 payment upon return of the failed belt or pulley by the original owner. For succeeding owners, this drive belt warranty shall cover belt or pulley parts only.
3. Rental units, demonstrators, prime power, or commercial applications, such as construction or utility, are warranted for (1) one year or 2,000 hours, whichever comes first.
4. This transferable warranty is in effect for all Recreational Vehicle Generators purchased after Jan. 1, 1998.

THIS WARRANTY DOES NOT COVER:

- Costs of maintenance, installation, and start-up.
- Failures due to (a) normal wear and tear from GN engine, or (b) accident, misuse, abuse, negligence or improper installation.
- Products which are modified or altered in a manner not authorized by Generac in writing.
- Any incidental, consequential or indirect damages caused by defects in materials or workmanship, or any delay in repair or replacement of defective parts.
- Failure due to misapplication.
- Telephone, telegraph, teletype or other communication expense.
- Living or travel expenses of persons performing service.
- Any and all transportation/travel expenses.
- Rental equipment used while warranty repairs are being performed.
- Overtime labor.
- Starting batteries, fuses, light bulbs, and engine fluids.

****NORMAL WEAR: As with all mechanical devices, the GN-Series engines need periodic parts service and replacement to perform well. This warranty will not cover repair when normal use has exhausted the life of a part or an engine.**

There is no other express warranty. Generac hereby disclaims any and all implied warranties, including but not limited to those of merchantability and fitness for a particular purpose to the extent permitted by law. The duration of any implied warranties which cannot be disclaimed is limited to the time period (one year) as specified in the express warranty. Liability for consequential, incidental or special damages under any and all warranties is excluded to the extent permitted by law. Some states do not allow limitations on how long an implied warranty lasts, or the exclusion or limitation of incidental or consequential damages, so the above limitations or exclusions may not apply to you. This warranty gives you specific legal rights and you may also have other rights, which vary from state to state.

For service, see your nearest GENERAC authorized warranty service facility or call 1-800-526-2871. Warranty service can be performed only by a GENERAC authorized service facility. This warranty will not apply to service at any other facility. At the time of requesting warranty service, evidence of original purchase date must be presented.

Generac Power Systems Inc.

P.O. Box 8 Waukesha, WI 53187 Telephone: (414) 473-5514 Fax: (414) 472-6505